

**CERTIFIED**

**UNE 149101**

**EQUIPMENT**

**RU**  
**WA**  
DIRECT FLOW 600

**MANUAL**

**REVERSE OSMOSIS  
EQUIPMENT**





DIRECT FLOW 600

## INDEX

## P

---

1	User manual	4
2	Technical manual	8
3	Sanitization procedure	14
4	Data sheet	18

# USER MANUAL

## MAIN FEATURES

---



**CLICK  
QUICK CONNECTIONS  
AND MAXIMUM SECURITY**



**FILTER CONTROL  
AUTOMATIC  
MAINTENANCE WARNINGS**



**SOLENOID VALVE  
IMMEDIATE CONTROL**



**DIRECTFLOW  
DIRECT PRODUCTION  
OSMOTIC WATER**



**STATUS LED  
STATUS INDICATIONS**



**HIGH PERFORMANCE PUMP  
HIGH MOTOR PERFORMANCE**



**SECURITY LOCK  
SECURITY LOCK**



**SMART  
FAUCET**



**ELECTRONIC ADAPTER  
GREATER SECURITY AND  
EFFICIENCY**



**DOUBLEFLOW  
GREATER FLOW  
DISPENSED WATER**



**DIRECT ACCESS  
EASY ACCESS  
AND MAINTENANCE**



**AUDIO WARNINGS  
SOUND WARNINGS**



**ANTISCALING PEARLS  
ANTISCALING PROTECTION**



**HIGH EFFICIENCY  
HIGH RECOVERY**



**CAPSULATED MEMBRANE  
CAPSULATED MEMBRANE**



**AUTO FLUSHING  
AUTOMATIC  
MEMBRANE FLUSH**



*Please keep this manual, which includes the service book and warranty sections, in order to provide you with better after-sales service.*

## 1. INTRODUCTION

Congratulations. You have purchased an excellent domestic water treatment equipment. This unit will help you to improve the properties of your water.

## 2. WHAT IS OSMOSIS?

The natural or direct osmosis is the most common in nature, given that semi-permeable membranes are part of the vast majority of organisms (for example plant roots, organs of our own body, cell membranes, etc ...).

When two solutions of different salt concentrations are separated by a semi-permeable membrane, in a natural way, a flow of water is produced from the solution with the lowest concentration to the one with the highest concentration. This flow continues until concentrations on both sides of the membrane are equal.

When this process is reversed to achieve a flow of water with a lower salt concentration from a higher concentration, sufficient pressure must be applied to the water with the highest concentration on the membrane to overcome the tendency and natural flow of the system. This process is what we call reverse osmosis. Nowadays, reverse osmosis is among the best methods to improve the properties of water by means of a physical system (without the use of chemical products).

The water to be treated exerts pressure on the semi-permeable membrane, so that part of it will be able to pass through the pores of the membrane (osmosis water), while the rest of the water (rejected or with a high concentration of salts) will be diverted to the drain (Fig. 1).

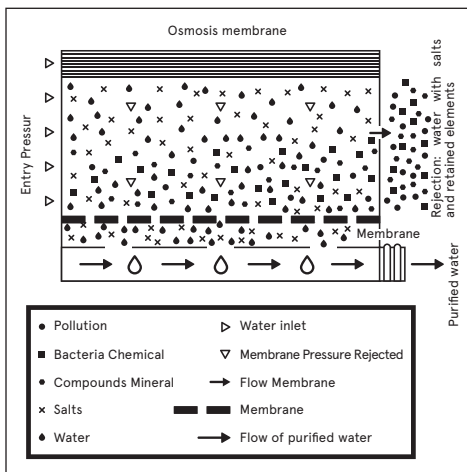

## 3. PRECAUTIONS

**! ATTENTION:** Read carefully the warnings described in the corresponding section of the Technical Manual.

**! ATTENTION:** This equipment is not a water purifier. If the water to be treated comes from a public supply (and therefore complies with current legislation), this equipment will substantially improve the quality of the water.

If the water to be treated does not come from a public supply network or is of unknown origin, it will be necessary to carry out a physical-chemical and bacteriological analysis of the water to ensure its correct potabilisation by applying the techniques and equipment suitable for each need, PRIOR TO INSTALLATION of the equipment. Please contact your distributor for advice on the most suitable treatment for your case.

The water treatment plants require periodic maintenance by qualified technical personnel in order to guarantee the quality of the water produced and supplied.

Except for service technicians, no one else is authorised to dismantle and repair, in order to avoid fire and electric shock.

### 3.1. USAGE OF EQUIPMENT

· When you will be gone for more than a week, close the water inlet tap to the equipment, empty it and disconnect it from the power supply (PUMP model). When you return, connect the power supply, open the inlet tap and the faucet. Let the water flow for at least 5 minutes before consuming water.

**! ATTENTION:** After an extended period (more than one month) in which the equipment has been found to be inoperative or not producing water, contact your dealer for proper sanitation and maintenance.

· Remove large amounts or full bottles and avoid occasional cup dispensing for better performance of the equipment.

**! ATTENTION:** Special attention should be devoted to the cleanliness and hygiene of the osmosis tap, at all times and especially at the time of periodic maintenance and sanitization. To do this, use a disposable single-use sanitizing spray and kitchen towel. Under no circumstances should a dish cloth or multipurpose cloth used for cleaning the kitchen be used.

· This appliance can be used by children aged from 8 years and above and persons with reduced physical, sensory or mental capabilities or lack of experience and knowledge if they have been given supervision or instruction concerning use of the appliance in a safe way and understand the hazards involved. Children should not play with the appliance. Cleaning and user maintenance shall not be made by children without supervision.

### 3.2. RECOMMENDATIONS FOR THE APPROPRIATE USE OF OSMOSIS WATER

· If you wish to feed any other consumption point with osmosed water (such as a fridge with an ice dispenser, another tap, etc...), the connection should not be carried out with a metal tube, as this would give the water a bad taste. Always use plastic tube.

**!** **ATTENTION:** *The water provided by the domestic osmosis equipment is **LOW MINERALIZATION**. The mineral salts needed by the human body are provided mainly by food, especially dairy products and to a less extent by drinking water.*

· We recommend not to use aluminium utensils to cook with osmosed water.

### 3.3 CONDITIONS FOR THE CORRECT USE AND FUNCTIONING OF THE EQUIPMENT

- The equipment must not be supplied with water at temperatures higher than 38°C, nor lower than 5°C.
- The ambient temperature must be between 4° and 45°C.
- For water with salinity higher than 1500 ppm, consult your distributor..

In the event that the water to be treated contains:

1. hardness greater than 15°F.
2. Concentrations of free chlorine > 1,2 mg/l.
3. High iron or manganese concentrations (greater than 1 mg/l measured at equipment rejection).
4. Turbidity greater than 3 NTU.
5. Nitrate concentrations > 100 mg/l.
6. Sulphate concentrations > 250 mg/l.

## 4. BASIC OPERATION

---

The operating steps of the system are described in the Technical Data Sheet section (page 20).

## 5. USER INTERFACE

---

**!** **ATTENTION:** *This equipment comes with an electronic controller that will manage in an efficient way, the functionality and indications of the state in which it is in, as well as the different security systems.*

The technical data sheet of the equipment describes the states in which the system can be found and the information provided by it (pages 18-22 of this manual).

## 6. MAINTENANCE

---

In order to ensure the quality of the water supplied by your equipment, it should be regularly maintained.

Read the corresponding section of the Technical Manual to see the maintenance frequency recommended (page 8 of this manual).

## 7. IDENTIFICATION AND RESOLUTION OF PROBLEMS

PROBLEM	POSSIBLE CAUSE	SOLUTION
1. External leakage of the equipment.	<ul style="list-style-type: none"> <li>• Breakage of some internal part of the equipment.</li> <li>• Bad connection of the installation.</li> <li>• Deterioration of a plastic tube.</li> <li>• Bad connection of the filter or membrane.</li> <li>• The equipment has not been correctly depressurized service first, before changing the membrane or filter.</li> </ul>	<ul style="list-style-type: none"> <li>• Check all the connections of the installation.</li> <li>• Let the machine depressurize correctly, and reinstall the filter or membrane.</li> <li>• In case of having to disassemble the equipment, call the technical service first.</li> </ul>
2. No production	<ul style="list-style-type: none"> <li>• No water supply.</li> <li>• No power supply.</li> <li>• Membrane blocked.</li> <li>• Transformer voltage less than 24 VDC.</li> <li>• Inlet filter blocked.</li> </ul>	<ul style="list-style-type: none"> <li>• Wait for the power supply to return.</li> <li>• Check the power supply to the house.</li> <li>• Check the voltage of the transformer.</li> <li>• Check the membrane and the inlet filter.</li> </ul>
3. Low production	<ul style="list-style-type: none"> <li>• Partially closed feed tap.</li> <li>• Filters / membrane in bad condition or exhausted.</li> <li>• Reject valve blocked, flow rate less than 1 litre per minute.</li> <li>• Pump blocked or with air trapped inside (cavitations).</li> <li>• Low temperature of the water supply to the equipment.</li> </ul>	<ul style="list-style-type: none"> <li>• Open it completely.</li> <li>• Replace the filter or membrane.</li> <li>• Replace reject valve.</li> <li>• Change pump in case of blockage.</li> <li>• Unplug and re-plug the equipment to perform a flushing and remove the air contained in the pump.</li> </ul>
4. Excessive production	<ul style="list-style-type: none"> <li>• Excessive chlorine entry into the membrane.</li> <li>• Rejection valve blocked, flow rate less than 1 litre per minute.</li> <li>• Excessively high feed water temperature &gt;38°C.</li> </ul>	<ul style="list-style-type: none"> <li>• Replace membrane.</li> <li>• Change of rejection valve.</li> <li>• The water temperature must be reduced below the limits.</li> <li>• Check the general installation of the enclosure, to eliminate heat sources.</li> </ul>
5. Unpleasant smell/taste	<ul style="list-style-type: none"> <li>• Membrane in bad condition.</li> <li>• The equipment has been stopped for a long time.</li> <li>• No sanitization has been carried out.</li> <li>• The sanitizing product has not been correctly purged.</li> </ul>	<ul style="list-style-type: none"> <li>• Replace membrane.</li> <li>• Perform disinfection.</li> <li>• Properly purge the device.</li> </ul>
6. White water color.	<ul style="list-style-type: none"> <li>• Air in the system. Microbubbles of air that disappear after a few seconds.</li> </ul>	<ul style="list-style-type: none"> <li>• This is not a problem. The appearance will disappear as the air is eliminated inside the equipment.</li> </ul>
7. Continuous dripping noise in drain.	<ul style="list-style-type: none"> <li>• Depressurisation of the device after production.</li> <li>• Inlet valve dirty, or in bad condition.</li> <li>• Membrane non-return valve (production) dirty, blocked or in bad condition.</li> </ul>	<ul style="list-style-type: none"> <li>• Wait a few minutes, and check if dripping stops. Clean or replace inlet valve. Check diaphragm check valve.</li> </ul>
8. The equipment does not start.	<ul style="list-style-type: none"> <li>• No water supply. No power supply. Inlet filter blocked.</li> <li>• Machine blocked by alarm.</li> <li>• High pressure switch defective.</li> </ul>	<ul style="list-style-type: none"> <li>• Check the condition of the general key and the equipment inlet.</li> <li>• Check the general power supply.</li> <li>• Replace the inlet filter.</li> <li>• If there is power supply, but the lights do not come on, contact the technical service.</li> <li>• Replace the high pressure switch.</li> </ul>
9. The equipment starts and stops constantly.	<ul style="list-style-type: none"> <li>• Leakage at production outlet.</li> <li>• Electric valve seals on external devices do not cut correctly and leak internally.</li> <li>• Production backflow preventer does not close correctly.</li> </ul>	<ul style="list-style-type: none"> <li>• Check osmosis water installation for leaks and repair.</li> <li>• Check the shut-off mechanisms of the devices connected to the equipment, and ensure correct shut-off.</li> <li>• If dispenser taps are installed, check for abnormal dripping and repair.</li> <li>• Check backflow preventers.</li> </ul>
10. The equipment never stops rejecting water to the drain.	<ol style="list-style-type: none"> <li>1. Inlet solenoid valve damaged.</li> <li>2. Deteriorated production check-valve.</li> </ol>	<ol style="list-style-type: none"> <li>1. Check and replace.</li> </ol>

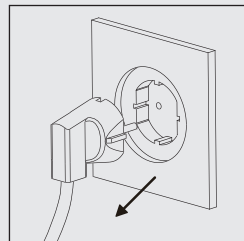
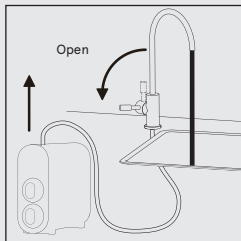
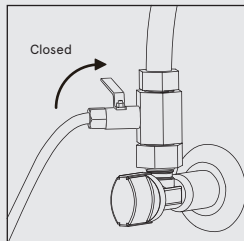

Read the section INTERFACE of the Technical Sheet. In case of anomaly, contact the SAT and proceed as indicated: Close the inlet valve. Open the tap to depressurize the system and unplug the plug.

# TECHNICAL MANUAL

## 1. MAIN FEATURES

---

### APPLICATION

#### **Water treatment**

**Reverse osmosis for domestic use.**

#### **Use**

Improvement of the characteristics of drinking water (that meets the requirements of the European Directive on water for human consumption 98/83 or its national transpositions in the different member states of the European Community).

#### **Modifications due to reduction or contribution**

· Water treatment using reverse osmosis is capable of reducing concentrations of salts and other substances in high percentages.

· Minimum reduction\* of certain compounds and parameters:

Sodium: 85%.

Calcium: 90%.

Sulfate: 90%.

Chloride: 90%.

Total hardness: 90%.

Conductivity: 90%.

\* Depending on the characteristics of the water to be treated (at the membrane outlet). These values may vary in depending on the type of post-filter that the equipment incorporates and/or regulation of the mixing valve (if it incorporates).



## 2. INSTALLATION

· In the event that the domestic installation has to be conditioned in order to install the equipment in the planned place, it must be carried out in accordance with the national regulations for indoor installations of water and electrical supplies.

· This equipment needs an electrical outlet less than 1 metre away (1).

· This equipment must not be installed either lying down or inclined (2), as the leaking sensor would be disabled. The equipment filled with water weighs more, the distribution of weights in an unexpected position could cause some connection element to be forced, which could cause a malfunction, damage to equipment components or loss of water.

· The place planned for its installation must have sufficient space for the appliance itself, its accessories, connections and for carrying out convenient maintenance (3).

· Under no circumstances will the equipment be installed outdoors (4).

· The environment and conditions where equipment and tap are installed must be kept in adequate hygienic-sanitary conditions.

· The appliance is only to be used with the power supply unit provided with the appliance.

- The equipment must only be supplied with a voltage between 100 and 240 VAC 50/60Hz.

- The adapter must be installed vertically on the wall or in the cabinet. Do not place the adapter flat on the bottom of the cabinet.

- Do not use damaged power supplies or plugs, or loose sockets.

- If the power cord is damaged, it must be replaced by a designated professional after-sales service technician in order to avoid hazards.

- Do not touch the power plug with wet hands.

- Do not use in conditions of high water pressure.

· Avoid external drips on the equipment, coming from pipes, drains, etc.

**!** **ATTENTION:** *The equipment must not be installed next to a heat source or directly receiving a flow of hot air over it (dryer, refrigerator, etc.). The new tube sets supplied with the appliance are to be used and that old tubes should not be reused.*

· The new hose sets supplied with the appliance must be used and the old hose sets must be removed accordingly.

### 2.1. COMMISSIONING AND MAINTENANCE

**!** **ATTENTION:** *The water treatment equipment requires periodic maintenance carried out by qualified technical personnel, in order to guarantee the quality of the water produced and supplied.*

- The consumable elements must be replaced as often as indicated by the manufacturer.

- The equipment must be sanitised periodically and before it is put into service.

- During the first 30 minutes after start-up, filter and/or membrane change, the quality of the water may vary up to its optimum operating performance.

## 3. UNPACKING

It is important that before installation and start-up, you check the box and the condition of the equipment, in order to guarantee that it has not been damaged during transport.

**!** **ATTENTION:** *Claims for damage during transport must be submitted together with the delivery note or invoice to your distributor, attaching the name of the carrier within a maximum period of 24 hours after receipt of the merchandise.*

Remove the equipment and accessories from their box, removing the corresponding packaging.

**!** **ATTENTION:** *Dispose of plastic bags properly and keep them out of the reach of children, as they can be a danger to them.*

Inside you will find: Water treatment equipment, installation accessories and documentation.

The materials used in the packaging are recyclable and must be disposed of in the appropriate separate collection containers or in the specific local centre for the recovery of waste materials.



This product cannot be disposed of together with normal municipal waste. When the useful life of the equipment has ended, it must be delivered to the company or centre where the device was purchased, or to a Recycling Point or specific local centre for the recovery of materials, indicating that it has electrical and electronic components.

The correct collection and treatment of useless appliances contributes to preserving natural resources and also to avoiding potential risks to public health.

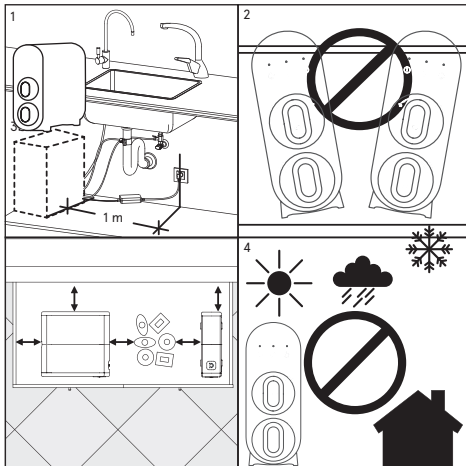

## 4. INSTALLATION

- The installation of your osmosis equipment must be carried out by personnel sufficiently qualified to do so. Read this manual first and consult your dealer in case of doubt.

**!** *Since the appliance to be installed improves the quality of the water to be consumed, all the tools to be used for assembly and installation must be clean and in no case may they be contaminated or impregnated of grease, oils or oxides. Use dedicated tools for tube cutting, membrane handling, etc. Keep them clean and disinfect them periodically.*

**!** *ATTENTION: The work must be carried out with a suitable hygienic attitude and conditions, taking extreme precautions in everything related to materials and components that are going to be in contact with the water to be treated or consumed.*

(For more information contact your dealer).

**!** *ATTENTION: Avoid the risks of external contamination of the equipment due to improper handling, using gloves, hand sanitizing gel or washing hands as many times as necessary throughout the installation, start-up and maintenance of the equipment.*

The most common place for installation of the unit is usually under the kitchen worktop or in an adjoining cabinet. Install the tap, drain collar and inlet adaptor and connect them to the respective connectors on the unit (5, 6 and 7).

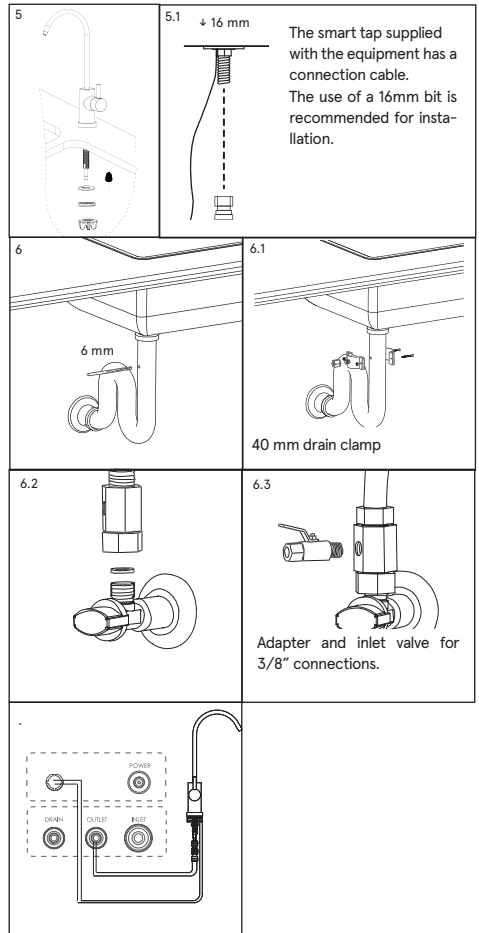

**!** *ATTENTION: Some of the installation accessories may vary depending on the model and the region in which the equipment is distributed.*

### 4.1. MIXING KIT

- In case you want to increase the pH, conductivity and chlorine concentration at the outlet, you must carry out the installation according to the following scheme and using the corresponding components included in the mixing kit (consult your distributor).

- After start-up, open the tap and with the corresponding meter for the parameter of interest, measure in the water dispensed from the tap and slowly and progressively open the mixing valve until the desired parameter is achieved.

- The water dispensed must comply with the drinkability requirements, established by European Directive 98/83 or the corresponding national legislation that transposes it.

See hydraulic scheme on page 13.

#### 4.2. INSTALLATION OF THE FILTERS

- Install the PP + CB + PCB filter (1) on the first stage of the equipment (upper position) and the RO membrane (2) on the second stage of the equipment (lower position).
- To install the filters, present each filter in its respective housing with the handle in a horizontal position, as shown in figure 8.
- Insert firmly all the way and turn the handle 90 degrees clockwise. After installation, the three filters should be as shown in figure 9.

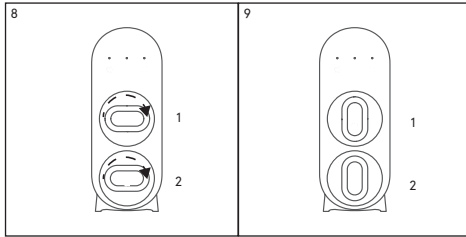

#### 5.4. RINSE AND CLEAN

- Open the tap of the equipment and measure the quality of the water that is being produced. With a conductivity or TDS meter, check that the reduction of salts obtained is adequate with respect to the water to be treated (10).

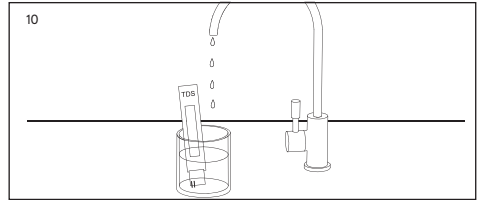

**!** **ATTENTION:** in case of detecting that the dispensed water does not comply with the current national legislation, carry out the measurement again. If the deviation persists, close the equipment inlet valve, drain it through the tap, disconnect it electrically and contact your technical service.

### 5. START-UP

#### 5.1. FILTER RINSING

- Once the filters are installed, the dispenser tap must be opened. Next, we will open the water inlet tap to the equipment and to finish, we will connect the power plug to the socket. The equipment will start to perform an internal flushing of filters and membrane, with the purpose of eliminating air bubbles, membrane protection products and cleaning the filters of possible residues. During this time, the production flow rate will be diminished by the flow of flushing the filters. In the case that the rejection flow to the drain takes a few minutes to come out, it is advisable to repeat the start-up steps, because the pump could have an air bubble, making it cavitate, without being able to give water flow to the rest of the components. Keep in mind that the programmed time for this flushing is 30 seconds.

#### 5.2. SANITISATION OF THE EQUIPMENT

- Sanitise the equipment according to the model and procedure indicated by the manufacturer (see Sanitisation Procedure). If in doubt, consult your distributor.

#### 5.3. SYSTEM TIGHTNESS, STOP AND START

- Close the dispensing tap of the equipment on the worktop and keep the equipment hydraulically or electrically powered by carrying out an ocular check of the system to ensure that there are no leaks (for approx. 5 minutes).

Open the dispenser tap. The equipment should activate and dispense water. Close the tap again and check that the equipment stops.

## 6. MAINTENANCE

---

**!** *ATTENTION: Some components of your equipment, such as the pre-filters and the membrane, are consumables that have a limited life.*

The duration will depend on the quality of the local water, consumption, type of use and specific aspects of the water to be treated such as extreme turbidity, high chlorination, excess iron, etc

### RECOMMENDED MAINTENANCE

---

PP + CB + PCB: 12 months or 6,000 lts.  
RO membrane: 36 months or 20,000 lts. (for treated soft water (hardness <15 °HF).

Maintenance must be carried out by trained personnel, who must handle the equipment properly, as well as use original spare parts to maintain the characteristics, guarantee, certifications and performance of the equipment

**!** *ATTENTION: The use of non-original spare parts, or the installation outside the operating limits and improper commissioning, maintenance or use, may lead to the loss of the guarantee, as well as the invalidation of the certifications to which submitted from the unit.*

An excess of any compound (total chlorine, turbidity, hardness, etc...) can cause a reduction in the life of filters and certain components. These maintenances are indicative.

Your distributor will anticipate the duration of the consumables depending on the characteristics of the water to be treated and the expected consumption in each case.

**!** *ATTENTION: All consumables are supplied in individual packaging specially designed to guarantee hygienic conditions for storage and transport. Exercise extreme hygiene precautions after removing the consumables from their packaging and when handling the various connectors and components.*

**!** *ATTENTION: Before dismantling the equipment, provide all the material you will need to carry out maintenance operations (read section 5 Installation) and the space necessary for this. Work in a well-lit place, in adequate hygienic conditions and with enough space to carry out operations comfortably.*

Carry out the filter change properly. Ensure the tightness of the joints and the original hydraulic configuration of the system as recommended by the manufacturer.

- Sanitize the equipment following the indications described in the Sanitation Procedure.
  - For more information, see the data sheet of the team.
- If you have any other questions, consult your dealer.

Hydraulic diagram..

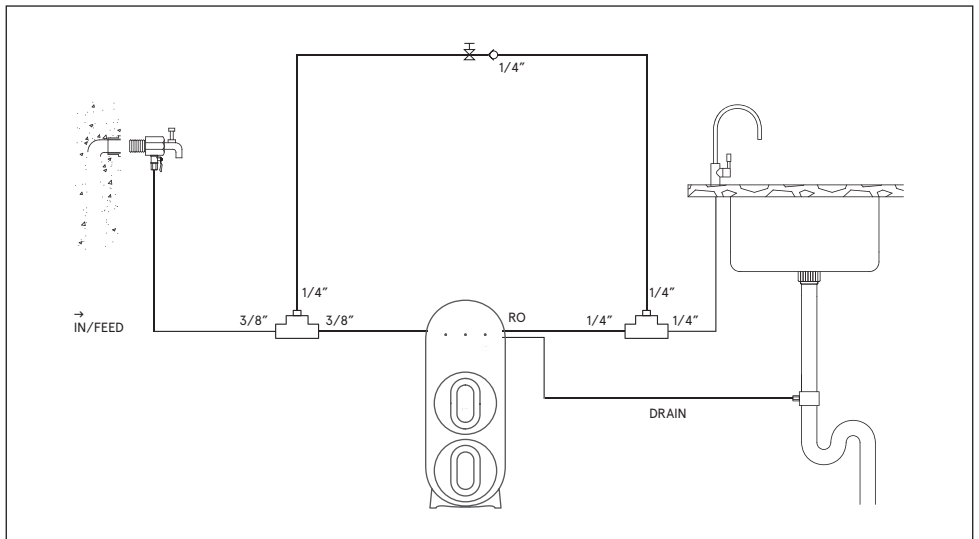

# SANITIZATION PROCEDURE

## 1. SANITIZING

Necessary material:

- Manual valve.
- Dosing housing and connectors.
- Oxibac (0.5 l).
- Brush.
- Single-use latex gloves.
- Easy-rinse soap or detergent.
- Food grade lubricant.
- Hydrogen peroxide detector strips.
- Sanitizing spray.
- Paper towel.

Sanization:

- During start-up.
- At least every 12 months.
- Whenever we handle components in contact with water.

**! ATTENTION: The water used during sanitation must be drinking water (from the public distribution network complying with the corresponding potability requirements of RD 140/2003, European directive 98/83 or current local legislation).**

- Open the tap and let water recirculate in order to renew the water inside the equipment.
- Close the inlet valve (1) and open the dispenser tap (2) to decrease the pressure in the equipment.

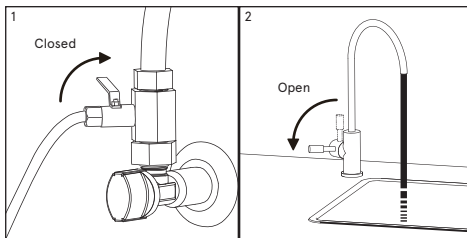

- Change the filters and flush them as indicated in the corresponding section of the equipment's Technical Manual. The sanitization must be carried out with the new pre-filters and post-filters installed and previously rinsed in an adequate way (the carbon dust from them has been correctly removed).
- Use single (3) use latex gloves to handle sanitizing products.

**! ATTENTION: Take extra hygiene measures when handling the filters, the membrane and the equipment components in contact with water. Use disposable gloves or wash your hands as many times as necessary to avoid risks of contamination of the equipment.**

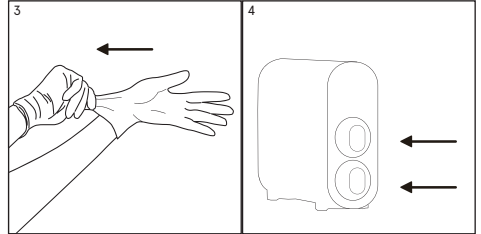

- In case of replacement of any of the cartridges for disposal, clean and dry the inside of the housing.
- Disinfect the cartridge connections with a brush (which must be kept clean and disinfected) and a suitable disinfectant.

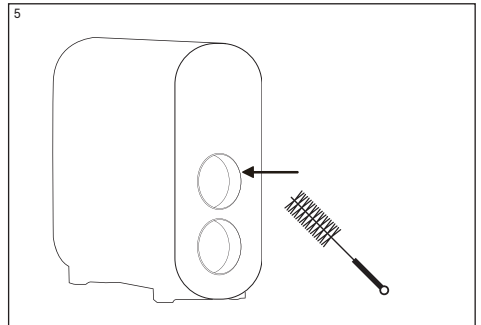

## 2. FILTER AND MEMBRANE TREATMENT

- Disconnect the inlet pipe to the equipment marked as "feed-inlet", and insert the dosing cup between the stopcock and the water inlet of the equipment (6). For greater convenience and ease of access during sanitising and the opening and closing operations of the inlet valve, a manual valve in the closed position can be inserted together with the sanitising dosing cup, which will perform the same functions as the manual shut-off valve at the inlet to the equipment.

- Once the assembly is installed, keep the new manual inlet valve closed and open the inlet valve connected to the wall adapter (7). The dosing cup must be empty.

- Pour 0.25 litres of Hydrogen Peroxide into the dosing cup inserted in the inlet of the unit (8). Screw the cup correctly to its head.

- The manual inlet valve and the tap must be closed. Connect the equipment to the power supply.

- Open the water inlet stopcock to the equipment and the dispenser tap, connect the device to the mains and allow it to start working and let it aspirate the Hydrogen Peroxide into it. Fill a 1L jug with the water from the dispenser tap. Before closing the dispenser tap, close the inlet tap again to lower the pressure. Fill the dispenser again with 0.25l of hydrogen peroxide and repeat the above steps and finish by closing the dispenser tap. At this point, the entire circuit contains sanitising liquid.

- After 10 minutes, open the dispenser tap (9) and let the mains water circulate for 5 minutes.

- Empty the dosing cup. Before opening the dosing cup, have a container within easy reach to empty it, as it may be full of water.

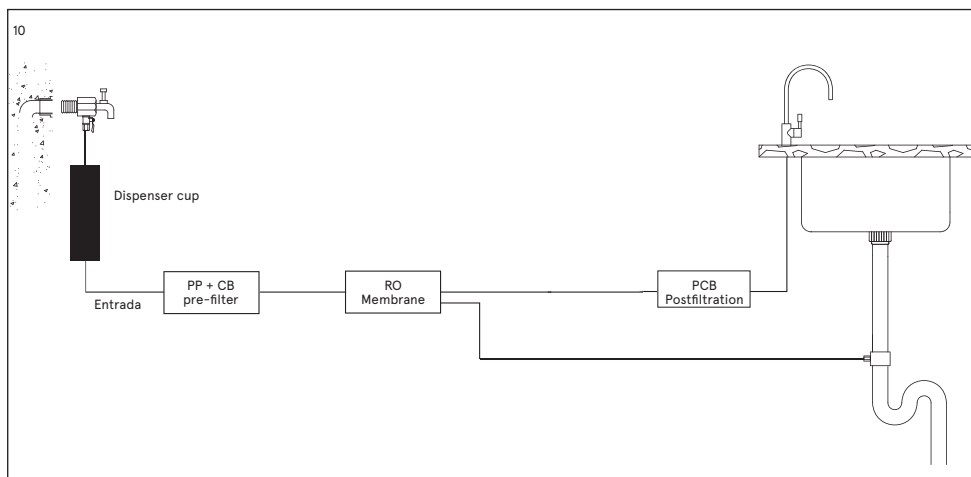
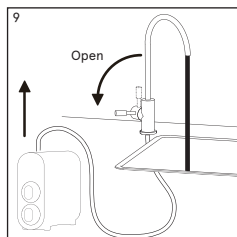
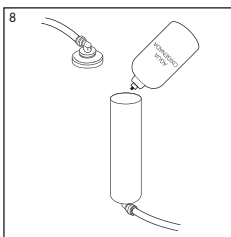
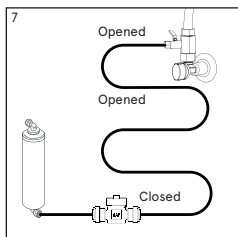
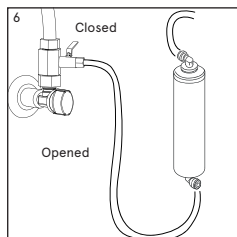

- Pay special attention to sanitizing the tap spout. Use the sanitizing spray (or, failing that, hydrogen peroxide, dosing it in such a way that it penetrates the tap) and single-use kitchen paper. Spray the spray on the tap nozzle (10), clean the spout and tap nozzle with the disposable paper and do not touch it directly with your hands (11).

### **3. RINSE**

---

- Once the sanitisation has been carried out, it shall be carried out:

- If the machine has just been installed, the system shall be flushed by letting the water flow out of the tap for 5 minutes.

- If the filter or membrane has been changed, reset the changed cartridge and let the water flow out of the tap for at least 5 minutes.

- Rinse with plenty of water that complies with the applicable local regulations regarding the parameters of water potability.

- At the end of the rinse, take a kitchen towel and dry all the parts that may have got wet, especially the Aquas-top leak detection probe (if the unit is equipped with one).





# DATA SHEET

## 1. TECHNICAL CHARACTERISTICS

### FUNCTIONING LIMITS

	PUMP SYSTEM*
Pressure (max./min.):	4 bar - 1 bar (400kPa-100kPa).
TDS (max.):	1500ppm**.
Temperature (max./min.):	38 °C - 5 °C.
Hardness (max.):	15 °HF. ***.

Control type: 1. Max. pressure switch  
2. Inlet control bypass solenoid valve

Security system: 1. Maintenance notice.  
2. Security leak system.

Dimensions (A x B x C mm): 335 x 132 x 410.

Peso (in kg, including all accessories): 12.45.

Inlet connection: 3/8".  
Drain connection: 1/4".  
Faucet connection: 1/4".  
Wall adapter: 3/8" M-F. \*\*\*\*  
Drain clamp: Clamp for 40 mm drain.

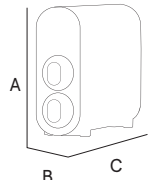
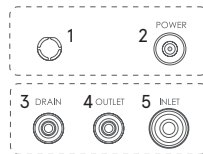

- 1. Data interface
- 2. "Power"
- 3. Drain
- 4. Faucet
- 5. Inlet

\* Flow rates may vary by 20% depending on the temperature, pressure and specific composition of the water to be treated.

\*\* For salinity higher than 1500ppm, please consult your distributor.

\*\*\* Higher hardness may reduce the life and performance of certain components.

\*\*\*\* May vary depending on the model.

(PP + CB) + (PCB)

1 x combined sediments / carbon + postfilter carbon block

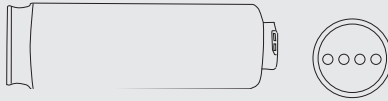

RO Membrane

1 x Membrana 600 GPD.

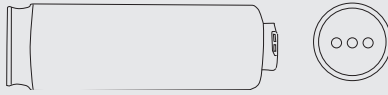

Caudal de agua osmotizada: 1,8 lpm.

Faucet type: Intelligent

Production: 1.8 lpm. (inlet water conditions 450 µS, 15 °HF, 17 °C and 3 bar)

Automatic membrane flushing system. Automated flushings.(SEE ap. 3.2)

Electric adapter:

Made by: FOSHAN SHUNDE GUANYUDA POWER SUPPLY CO LTD

Model: GE98-240400-2DG

Inlet voltage 100-240 Vac

Work frequency 50 / 60 Hz

Outlet voltage: 22,8-25,2VDC

Outlet current: 4A

Power: 96W

Average efficiency: 88% min. Efficiency at maximum load: 79% mln

Idle consumption: 0,21W

## HYDRAULIC DIAGRAM

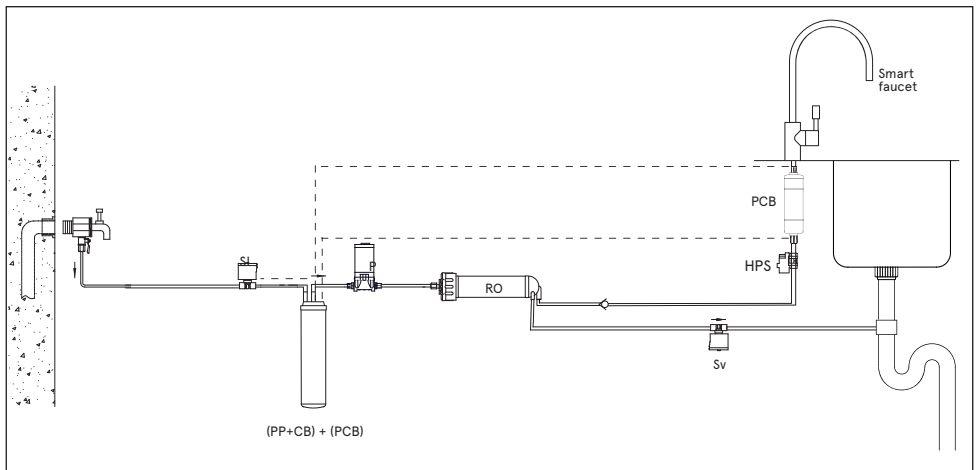

## HYDRAULIC CONNECTION DIAGRAM

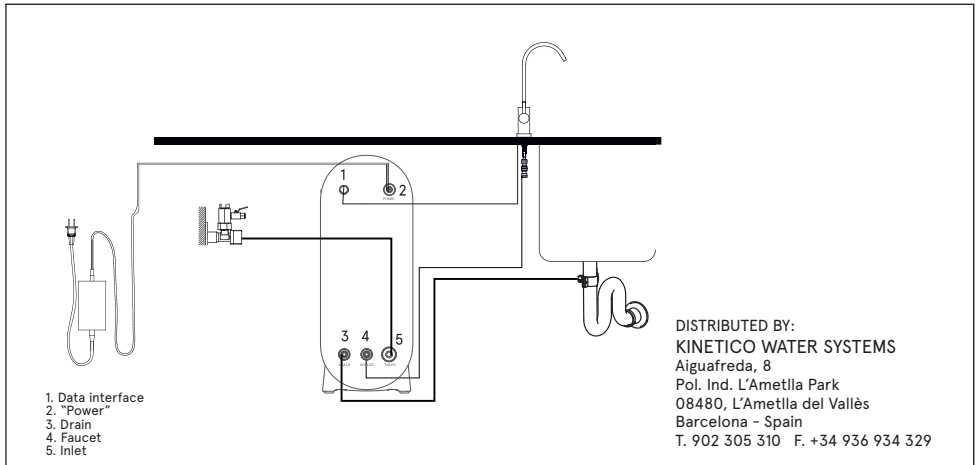

## 2. WORKING OF THE EQUIPMENT

- The mains water to be treated enters the equipment through the prefiltration stage, which incorporates a sediment and carbon PP + CB filter. In this filtration stage, suspended particles, chlorine, its derivatives and other organic substances are retained.

- The flow of water into the equipment is controlled by a shut-off solenoid valve (Si).

- The water, after being treated at the filtration stage, is driven towards the reverse osmosis membrane (RO). Inside the membrane there are polyphosphate pearls to reduce membrane scaling. The equipment incorporates a pump (P) to increase the pressure. The pressure of the water on the membrane makes the reverse osmosis process possible.

- The reject water or water with excess salts and other dissolved substances is directed to the drain for disposal.

- The direct flow units are controlled by a pressure switch (HPS).

- Before exiting through the dispenser tap, the water passes through the carbon block postfilter (PCB), which enhances the taste.

- The equipment incorporates different functional and/or safety systems, managed by a state-of-the-art electronic module:

- Automatic filter change warning, in order to inform the user that proper maintenance must be performed to ensure the quality of the dispensed water.

## 3. INTERFACE SYSTEM STATUS

### 3.1 DISPLAY:

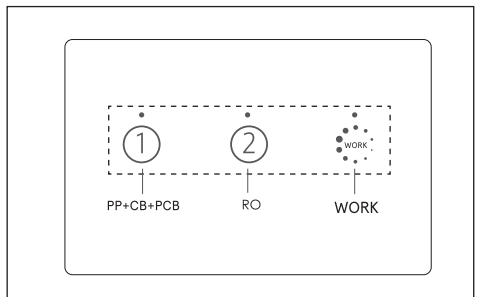

The equipment includes an intelligent faucet that will indicate by means of an LED the need to replace any of the cartridges or a malfunction of the system.

Fixed BLUE LED:

- In production.

BLUE LED flashing:

- Flushing

ORANGE LED flashing:

- Maintenance warning (filter reaching end of life)

Fixed ORANGE LED:

- Filter change (filter at end of life) or safety lockout
- Malfunction (excessive running time continuously)

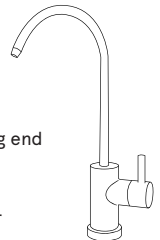

### 3.2. FILTER AND STATUS INDICATORS

<b>FUNCTION</b>	<b>ACTION</b>	<b>LIGHT STATUS</b>
1. <b>Flushing on the electrical power-up of the equipment.</b>	When the system is turned ON the RO will flush the membrane for about 30 secs.	Every light flashes on BLUE while flushing is going on.
2. <b>Daily flushing.</b>	The system will flush the membrane for about 30 secs every 24 hours.	Every light flashes on BLUE while flushing is going on.
3. <b>Opening of the faucet</b>	System is put into normal mode operation.	When equipment is functioning, the functioning light is ON.
4. <b>Close the faucet.</b>	System stops producing water and sets itself on stand-by.	Every light is OFF
5. <b>System power-up.</b>	System powers-up	After switching on the power supply, 3 beeps are emitted and all the lights are lit in VIOLET color. After 5 seconds, the machine performs the initial flush.

### 3.3. FAULT IDENTIFICATION AND RESOLUTION

<b>FUNCTIONS</b>	<b>ACTIONS</b>	<b>LED STATUS</b>
1. Protection for continuous operation time of the pump.	The pump has been running for +120 minutes at a time. Disconnect and reconnect the electrical power.	The operation light flashes RED. 1 second beeps for 1 minute.
2. Filter change safety lock.	After 3 months from the end of life of the filters without maintenance, it will be blocked to guarantee the quality and characteristics of the water dispensed by the machine. Call the technical service to perform the maintenance.	Fixed corresponding red LED

*When you detect that the equipment is in one of the states described above, contact the maintenance service to make an appointment to carry out the required repair or maintenance.  
See the corresponding section in the technical manual.*

### 3.4. FILTER LIFE TIME DISPLAY

LIFE SPAN	REMAINING LIFESPAN (DAYS)	% OF REMAINING CAPACITY	DISPLAY	WARN	ACOUSTIC
Normal.	> 30	< 95%	BLUE Fixed		No alarm.
Pre-notice.	$0 < X \leq 30$	> 95% < 100%	Blinking red LED		No alarm.
Exhausted.	$\leq 0$	> 100%	Fixed red LED.		Beeping when dispensing water.
Security lock.	$\leq 0$	> 100%	Displays OFF..		No beepings

**!** *To guarantee the quality and characteristics of the water dispensed by the equipment, it is important to perform the appropriate maintenance periodically and/or when indicated by the equipment's own electrical controller. If this is not done within 3 months from the maintenance notice, the equipment will stop its operation for safety, stopping dispensing water and warning and informing the user of the reason for this stoppage.*





## 4. WARRANTY

The distributor guarantees the equipment for a period of three years against any lack of conformity detected in the equipment, as stipulated in Royal Decree-Law 7/2021, of 27 April, on the transposition of European Union directives in the areas of competition, prevention of money laundering, credit institutions, telecommunications, tax measures, prevention and repair of environmental damage, posting of workers in the provision of transnational services and consumer protection.

- The guarantee includes the repair and replacement of defective parts by personnel authorised by the distributor or by the official technical assistance service (S.A.T.) at the place of installation or in its workshops. The warranty includes labour and shipping costs that may be incurred.

- The distributor is exonerated from providing warranty in cases of parts subject to natural wear and tear, lack of maintenance, knocks or other non-conformities resulting from improper use of the equipment or inadequate use according to the operating conditions and limits indicated by the manufacturer of the equipment. Likewise, the guarantee loses effectiveness in cases of improper handling and use of the equipment or in those cases in which they have been modified or repaired by personnel outside the distribution company or official S.A.T.

- The parts replaced under warranty will remain the property of the distributor.

- The distributor is liable for the lack of conformity of the equipment when this refers to the origin, identity or suitability of the products, in accordance with their nature and purpose. Taking into account the characteristics of the equipment, it is essential for the guarantee to cover the lack of conformity, the fulfilment of the technical conditions of installation and operation. Failure to comply with these conditions may result in the absence of warranty, taking into account the relevance of the purpose of the equipment and the operating conditions and limits under which it must operate.

- The distributor must guarantee that the equipment installed is suitable for improving the quality of the water to be treated in particular, according to the characteristics of the equipment and the regulations in force.

- The distributor must guarantee the correct installation and commissioning of the equipment as indicated by the manufacturer and current regulations and will also be responsible for any lack of conformity derived from incorrect application, installation or commissioning of the equipment.

- For any warranty claim, it is necessary to present the purchase invoice. The three-year period is calculated from the purchase of the equipment from the distributor.

- If during the warranty period your equipment presents any problem, please contact your distributor.

### The equipment is installed and operating satisfactorily for the client and for the record:

\* Treatment prior to equipment:

\* Hardness of entrance to the equipment(°F):

\* Input TDS to the equipment (ppm):

\* TDS produced water (ppm):

\* Equipment inlet pressure(bar):

### \* Result of the installation and commissioning sheet:

Correct:

Other:

*The owner of the equipment has been adequately and clearly informed of the use, handling and maintenance that the equipment requires to guarantee its correct operation and the quality of the water produced. A maintenance contract is offered for this purpose.*

\*Ref. Contract of maintenance:

ACCEPT the maintenance contract

DO NOT ACCEPT the maintenance contract

*In case you need information, report a breakdown or malfunction, request maintenance or intervention by a technician, first read the sections on operation, detection and resolution of problems in this manual and contact the dealer or company that sold you your equipment.*

COMPANY AND/OR AUTHORIZED INSTALLER, DATE AND SIGNATURE: NÚMERO DE SERIE:



**NOTE FOR THE COMPANY AND/OR TECHNICIAN/INSTALLER AUTHORIZED:** the data marked with the symbol \* must be filled in by the installer technician and transcribe it himself from the INSTALLATION RECORD sheet.





## 5. INSTALLATION RECORD SHEET



**NOTES FOR THE TECHNICIAN/INSTALLER:** read this carefully Handbook. In case of any doubt, contact the Technical Assistance Service (SAT) of your distributor. The data marked with the symbol \* must be filled in by the technician/installer and transcribed by him/her on the WARRANTY sheet. This sheet must be kept by the installer and may be required by the distributor in order to improve after-sales service and customer service to the client. The technician who performs the installation and commissioning of the equipment must have the training proper technique.

### DATA ON THE APPLICATION OF THE EQUIPMENT:

Origin of water to treat:

PUBLIC SUPPLY

OTHERS

\* Treatment prior to equipment:

\* Hardness of entrance to the equipment(°F):

\* Input TDS to the equipment (ppm):

\* TDS produced water (ppm):

\* Equipment inlet pressure(bar):

\* Equipment inlet chlorine concentration (ppm):

### CONTROL OF THE INSTALLATION STEPS:

Sanitization according to protocol described  
Maximum pressure switch setting  
Review and fittings  
Pressurized system tightness

Produced water TDS (countertop tap) (ppm)  
Clearly report the use, handling and maintenance that the equipment required to guarantee its proper functioning and the quality of the water produced.

### COMMENTS

\* Result of installation and commissioning:

CORRECT (equipment installed and working correctly. Produced water suitable for the application).

OTHERS :

### IDENTIFICATION OF THE TECHNICIAN/INSTALLER AUTHORIZED:

COMPANY AND/OR AUTHORIZED INSTALLER, DATE AND SIGNATURE:

### CONFORMITY FROM THE EQUIPMENT OWNER:

I have been clearly informed of the use, handling and maintenance required by the installed equipment, having been offered a maintenance contract and informed of how to contact a Customer Service in case of requesting information, communication of failure or malfunction, request for maintenance or intervention of a technician.

Comments:

\*Ref. Contract of maintenance:

ACCEPT the maintenance contract

DOES NOT ACCEPT the maintenance contract

Model/Ref.:

Owner:

Street:

Telephone:

Population:

Province:

ZIP:

### SERIAL NUMBER:

### EQUIPMENT WARRANTY ADDRESSED TO THE DISTRIBUTOR:

The distributor will only be responsible for the substitutions of parts in case of non-conformity. The repair of equipment and the expenses that it entails (labor, shipping costs, travel, etc.) will be assumed by the distributor, in accordance with what was agreed in the general conditions of contracting and sale, for which reason may be subsequently passed on to the manufacturer.



### 6. MAINTENANCE SERVICE

DATE	TYPE OF SERVICE	NAME, SIGNATURE AND STAMP OF THE AUTHORIZED TECHNICIAN	
<input type="text"/>	<input type="radio"/> START UP		
<input type="text"/>	<input type="radio"/> COMPLETE MAINTENANCE	TECHNICAL <input type="text"/>	<input type="radio"/> ORDINARY <input type="radio"/> EXTRAORDINARY <input type="radio"/> WARRANTY
<input type="text"/>	<input type="radio"/> PREPARATION	STAMP	
<input type="text"/>	<input type="radio"/> SANITIZATION	<input type="text"/>	
<input type="text"/>	<input type="radio"/> OTHERS		
<input type="text"/>	<input type="radio"/> COMPLETE MAINTENANCE	TECHNICAL <input type="text"/>	<input type="radio"/> ORDINARY <input type="radio"/> EXTRAORDINARY <input type="radio"/> WARRANTY
<input type="text"/>	<input type="radio"/> PREPARATION	STAMP	
<input type="text"/>	<input type="radio"/> HIGIENIZACIÓN	<input type="text"/>	
<input type="text"/>	<input type="radio"/> OTROS		
<input type="text"/>	<input type="radio"/> COMPLETE MAINTENANCE	TECHNICAL <input type="text"/>	<input type="radio"/> ORDINARY <input type="radio"/> EXTRAORDINARY <input type="radio"/> WARRANTY
<input type="text"/>	<input type="radio"/> PREPARATION	STAMP	
<input type="text"/>	<input type="radio"/> SANITIZATION	<input type="text"/>	
<input type="text"/>	<input type="radio"/> OTHERS		
<input type="text"/>	<input type="radio"/> COMPLETE MAINTENANCE	TECHNICAL <input type="text"/>	<input type="radio"/> ORDINARY <input type="radio"/> EXTRAORDINARY <input type="radio"/> WARRANTY
<input type="text"/>	<input type="radio"/> PREPARATION	STAMP	
<input type="text"/>	<input type="radio"/> SANITIZATION	<input type="text"/>	
<input type="text"/>	<input type="radio"/> OTHERS		
<input type="text"/>	<input type="radio"/> COMPLETE MAINTENANCE	TECHNICAL <input type="text"/>	<input type="radio"/> ORDINARY <input type="radio"/> EXTRAORDINARY <input type="radio"/> WARRANTY
<input type="text"/>	<input type="radio"/> PREPARATION	STAMP	
<input type="text"/>	<input type="radio"/> SANITIZATION	<input type="text"/>	
<input type="text"/>	<input type="radio"/> OTHERS		

## 6. MAINTENANCE SERVICE

DATE	TYPE OF SERVICE	NAME, SIGNATURE AND STAMP OF THE AUTHORIZED TECHNICIAN	
<input type="text"/>	<input type="radio"/> START UP		
<input type="text"/>	<input type="radio"/> COMPLETE MAINTENANCE	TECHNICAL <input type="text"/>	<input type="radio"/> ORDINARY  <input type="radio"/> EXTRAORDINARY  <input type="radio"/> WARRANTY
<input type="text"/>	<input type="radio"/> PREPARATION	STAMP	
<input type="text"/>	<input type="radio"/> SANITIZATION	<input type="text"/>	
<input type="text"/>	<input type="radio"/> OTHERS		
<input type="text"/>	<input type="radio"/> COMPLETE MAINTENANCE		
<input type="text"/>	<input type="radio"/> PREPARATION	STAMP	
<input type="text"/>	<input type="radio"/> SANITIZATION	<input type="text"/>	
<input type="text"/>	<input type="radio"/> OTHERS		
<input type="text"/>	<input type="radio"/> COMPLETE MAINTENANCE		TECHNICAL <input type="text"/>
<input type="text"/>	<input type="radio"/> PREPARATION	STAMP	
<input type="text"/>	<input type="radio"/> SANITIZATION	<input type="text"/>	
<input type="text"/>	<input type="radio"/> OTHERS		
<input type="text"/>	<input type="radio"/> COMPLETE MAINTENANCE		TECHNICAL <input type="text"/>
<input type="text"/>	<input type="radio"/> PREPARATION	STAMP	
<input type="text"/>	<input type="radio"/> SANITIZATION	<input type="text"/>	
<input type="text"/>	<input type="radio"/> OTHERS		
<input type="text"/>	<input type="radio"/> COMPLETE MAINTENANCE		TECHNICAL <input type="text"/>
<input type="text"/>	<input type="radio"/> PREPARATION	STAMP	
<input type="text"/>	<input type="radio"/> SANITIZATION	<input type="text"/>	
<input type="text"/>	<input type="radio"/> OTHERS		



## 6. MAINTENANCE SERVICE

DATE	TYPE OF SERVICE	NAME, SIGNATURE AND STAMP OF THE AUTHORIZED TECHNICIAN	
<input type="text"/>	<input type="radio"/> START UP		
<input type="text"/>	<input type="radio"/> COMPLETE MAINTENANCE	TECHNICAL <input type="text"/>	<input type="radio"/> ORDINARY <input type="radio"/> EXTRAORDINARY <input type="radio"/> WARRANTY
<input type="text"/>	<input type="radio"/> PREPARATION	STAMP	
<input type="text"/>	<input type="radio"/> SANITIZATION	<input type="text"/>	
<input type="text"/>	<input type="radio"/> OTHERS		
<input type="text"/>			
<input type="text"/>	<input type="radio"/> COMPLETE MAINTENANCE	TECHNICAL <input type="text"/>	<input type="radio"/> ORDINARY <input type="radio"/> EXTRAORDINARY <input type="radio"/> WARRANTY
<input type="text"/>	<input type="radio"/> PREPARATION	STAMP	
<input type="text"/>	<input type="radio"/> HIGIENIZACIÓN	<input type="text"/>	
<input type="text"/>	<input type="radio"/> OTROS		
<input type="text"/>			
<input type="text"/>	<input type="radio"/> COMPLETE MAINTENANCE	TECHNICAL <input type="text"/>	<input type="radio"/> ORDINARY <input type="radio"/> EXTRAORDINARY <input type="radio"/> WARRANTY
<input type="text"/>	<input type="radio"/> PREPARATION	STAMP	
<input type="text"/>	<input type="radio"/> SANITIZATION	<input type="text"/>	
<input type="text"/>	<input type="radio"/> OTHERS		
<input type="text"/>			
<input type="text"/>	<input type="radio"/> COMPLETE MAINTENANCE	TECHNICAL <input type="text"/>	<input type="radio"/> ORDINARY <input type="radio"/> EXTRAORDINARY <input type="radio"/> WARRANTY
<input type="text"/>	<input type="radio"/> PREPARATION	STAMP	
<input type="text"/>	<input type="radio"/> SANITIZATION	<input type="text"/>	
<input type="text"/>	<input type="radio"/> OTHERS		
<input type="text"/>			
<input type="text"/>	<input type="radio"/> COMPLETE MAINTENANCE	TECHNICAL <input type="text"/>	<input type="radio"/> ORDINARY <input type="radio"/> EXTRAORDINARY <input type="radio"/> WARRANTY
<input type="text"/>	<input type="radio"/> PREPARATION	STAMP	
<input type="text"/>	<input type="radio"/> SANITIZATION	<input type="text"/>	
<input type="text"/>	<input type="radio"/> OTHERS		
<input type="text"/>			

## 6. MAINTENANCE SERVICE

DATE	TYPE OF SERVICE	NAME, SIGNATURE AND STAMP OF THE AUTHORIZED TECHNICIAN	
<input type="text"/>	<input type="radio"/> START UP		
<input type="text"/>	<input type="radio"/> COMPLETE MAINTENANCE	TECHNICAL <input type="text"/>	<input type="radio"/> ORDINARY  <input type="radio"/> EXTRAORDINARY  <input type="radio"/> WARRANTY
<input type="text"/>	<input type="radio"/> PREPARATION	STAMP	
<input type="text"/>	<input type="radio"/> SANITIZATION	<input type="text"/>	
<input type="text"/>	<input type="radio"/> OTHERS		
<input type="text"/>	<input type="radio"/> COMPLETE MAINTENANCE		
<input type="text"/>	<input type="radio"/> PREPARATION	STAMP	
<input type="text"/>	<input type="radio"/> SANITIZATION	<input type="text"/>	
<input type="text"/>	<input type="radio"/> OTHERS		
<input type="text"/>	<input type="radio"/> COMPLETE MAINTENANCE		TECHNICAL <input type="text"/>
<input type="text"/>	<input type="radio"/> PREPARATION	STAMP	
<input type="text"/>	<input type="radio"/> SANITIZATION	<input type="text"/>	
<input type="text"/>	<input type="radio"/> OTHERS		
<input type="text"/>	<input type="radio"/> COMPLETE MAINTENANCE		TECHNICAL <input type="text"/>
<input type="text"/>	<input type="radio"/> PREPARATION	STAMP	
<input type="text"/>	<input type="radio"/> SANITIZATION	<input type="text"/>	
<input type="text"/>	<input type="radio"/> OTHERS		
<input type="text"/>	<input type="radio"/> COMPLETE MAINTENANCE		TECHNICAL <input type="text"/>
<input type="text"/>	<input type="radio"/> PREPARATION	STAMP	
<input type="text"/>	<input type="radio"/> SANITIZATION	<input type="text"/>	
<input type="text"/>	<input type="radio"/> OTHERS		





