

Reverse Osmosis Compact Series

Technical Manual



Please read these installation and operation instructions for your Kinetico RO-Compact System carefully. We recommend that you keep this manual for future reference and pass it on to any future owners.

Manufacturer:

Kinetico Denmark, Sandvadsvej 7, 4600 Køge

Series type:



RO-Compact 1, RO-Compact 2, RO-Compact 3

Contents

Kinetico RO-Compact Range	8
Additional Equipment Components	10
Operating Conditions	12
The Components	14
Installation	20
Plumbing Connections	22
Operation and Maintenance	24
Using the RO-Compact System	28
Routine Maintenance	30
Troubleshooting	31
Maintenance	
Timetable	33
Solenoid Valve	34
Feed Pump	35
Flow Restrictor	36
RO-Compact 1 Parts	38
RO-Compact 2 Parts	49
RO-Compact 3 Parts	59
Electrical Parts	71
Electrical Boxes	72
Terminal Block Wiring	74
Flow Diagrams	77
Dimensions	81
Daily Log	82
CE Declaration of Conformity	83

The Kinetico RO-Compact Series is designed to demineralize cold-water (max 25°C) subsequent use in commercial dishwashers.

The Kinetico RO-Compact Series may only be used for this purpose, and in accordance with the operating instructions provided.

	Description: Reverse Osmosis	
Model: RO-Compact	Voltage: 230V/50Hz	
Snr. Dato0 100481	Full load current: 10 A	
Manufactured by:	Power consumption: 1,7 kw	
Kinetico Denmark	Sound pressure level is less than 70 db	
Sandvadsvej 7 4600 Køge	Max. Pressure: 7 bar	
Tlf. 56651400 www.kinetico.dk	Min. Pressure: 1 bar	
Made in Denmark	Max. Temperature 25 °C.	
Start date:		

You will see the following symbols used throughout this manual. They help to highlight issues that are relevant to the safe operation of this equipment.

The symbols will be used in the following instances:



General information regarding the product:

Includes technical specifications and expected operational results.



Isolate electrical power:

Use appropriate isolation procedures when servicing.



Maintain safe pressure:

Safe operating pressure range.



Consult Maintenance Section:

Refer to the maintenance section for specific instructions.



Consult Equipment Specifications Section:

Refer to the equipment specifications section for specific instructions.



Consult MSDS Sheets



A caution icon will be used to present any information that may hold a potential hazard or concern during the installation, use or maintenance of this product.

Should this information not be followed, it may result in damage of this equipment and its surroundings.



Electrical shock or electrocution hazard



Pinch point or crushing hazard



Chemical hazard



The warning icon will be used to present any information that may result in a severe hazard or concern during the installation, use or maintenance of this product. **Should this information not be followed, it may result in severe physical harm.**



Stay Clear



Do Not Touch



No Access:

Only properly trained and authorised persons may service or open panel.



Any tools or materials required during the installation, use or maintenance of this equipment will be preceded by this icon. Using these specific tools will minimise time and effort. Not using the proper tool may result in damage to this equipment, its surroundings or even physical harm.

**Safety instructions:****The RO-Compact is safe to operate if the following safety instructions are followed.**

- Start-up may only be performed by an authorised Kinetico service technician.
- The RO-Compact may only be connected to a dishwasher.
- The raw water must be of a tap water quality.
- The device only to be operated as described in these operating instructions.
- Do not use the device until you have read and understood the operating instructions, and have been briefed in person by a technician on its work specifics and operation.
- Danger of electric shock: do not open any outer coverings, if a tool is required for this purpose. Do not interfere with the electrical equipment of the device yourself, but always consult a specialist (electrician/Kinetico service technician).
- The RO-compact must be connected to the cold water supply (max 25°C).
- Faults, which cannot be traced to the on-site water or power supply, should be reported to Kinetico Dealer.
- STOP the water supply immediately if a leak occurs anywhere in the device. Unplug the device at the mains to disconnect it from the power supply.
- The RO-Compact may only be installed in a frost-protected location.
- The RO-Compact may only be installed in rooms with floor drain.
- Make sure to not bend or trap any hoses or cables, when moving or cleaning the device.
- Do not block ventilation grids.
- Do not spray the RO-compact with a hose or high-pressure / steam-jet cleaner.

Kinetico RO-Compact Range



The RO-Compact Range works on both a peak/batch delivery operation (reserve volume) and a continuous flow operation (rated hourly production).

Recovery times relate to the continuous production capacity of the unit.

System features include:

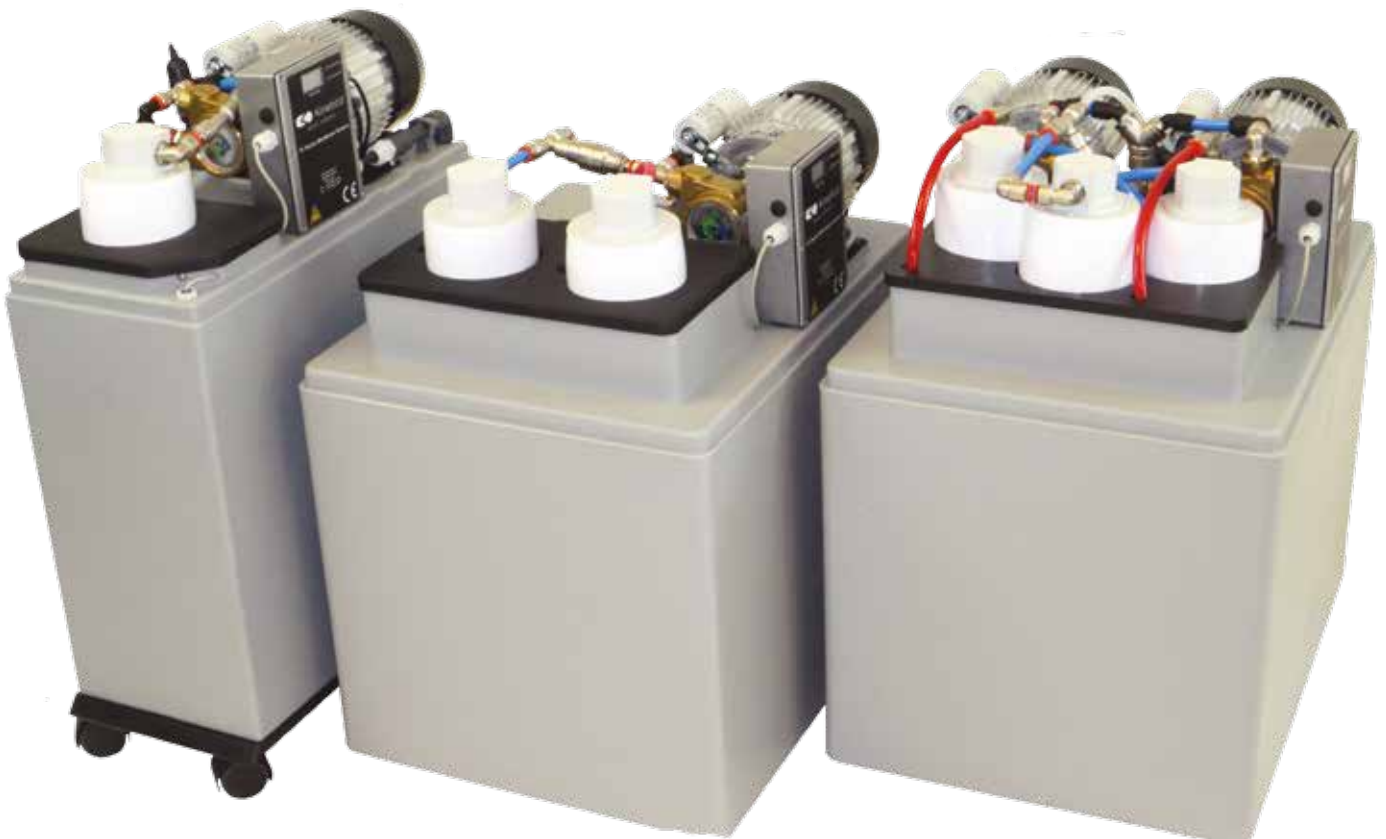
- Integrated Circuit Board Controller
- Batch Flow Meter
- Portable Cabinet Design
- Inlet Booster Pump
- Delivery Pump
- Everclean™, Permeate Rinse
- Low Energy Thin Film Composite Membrane



Part numbers for RO-series	RO-Compact 1	RO-Compact 2	RO-Compact 3
			
System with Integrated Bypass	170151	170152	170153
System with No-Bypass	170151-U	170152-U	170153-U
Minimum Rated Hourly Production@ 15 °C Litres/hour	160	300	420
Minimum Daily Production¹ Litres/day	3840	7200	10080
Reservoir Volume Litres	35	66	66
Recovery Time of Reservoir Minutes	14	14	10
Recovery (Hard Water Feed) Max. 10`dh	50%	50%	50%
Recovery (Hard Water Feed) Max. 25`dh	40%	-	-
Recovery (Soft Water Feed)	75%	75%	75%
Delivery Flow Rate Litres/hour	1250	1250	1250
Delivery Pressure bar	3,5	3,5	3,5
Membrane Type	Compact low3-4021	Compact low3-4021	Compact low3-4021
Number of Membranes	1	2	3
Sound Pressure Level² db	61	62	61

¹Based on feed TDS of 500 mg/l and a water temperature of 15 °C.

²Sound measured 1 m from the front of the unit and 1,6 m from the floor with the lid on.

Additional Equipment Components

Depending on the inlet characteristics of your water, additional components may be required with your RO-Compact unit.

The install configurations of these accessories, along with a description of their functionality, can be found below. Should you require further information, or if you are unsure as to your individual requirements, please contact your Kinetico distributor.

Backwashing Filter:

The RO-Compact does not use a cartridge pre-filter to remove suspended solids (TSS). Feed water with a high level of suspended solids or turbidity, may require additional pre-filtration.

Kinetico has a wide range of backwashing filters which use a variety of media. Depending on the type of solids in the water, the appropriate media can be matched to your application.

The Kinetico laboratory can test for the TSS content of feed water, if unknown, to determine the pre-filter required.

High levels of TSS can cause fouling of the Compact membrane, thus reducing both the quality and quantity of the permeate water.

Carbon Filter:

A carbon filter is used to protect the compact membrane from organic fouling and chlorine degradation.

Both these types of fouling can seriously damage the membrane of the RO.

With chlorine degradation, the membrane is slowly and permanently damaged.



Maximum influent level of chlorine to compact membrane is 0.05 mg/l.

Prolonged exposure to excessive levels of chlorine will cause the membrane to be destroyed. It would then need to be replaced.

Softener:

Hardness levels will affect the performance of the RO-Compact system.

Depending on the inlet hardness level, a varying level of system recovery is recommended. With a hardness level above 10° dH, the system should be pre-treated to reduce hardness contamination on the membrane.

Calcium and magnesium are the two primary constituents of hardness that lead to scale build-up on the RO's membrane. To prevent this type of scaling, a softener can be used to remove calcium and magnesium from the water.

A chemical de-scaling may be substituted for pre-softening the water in some applications. However, some chemical additives may result in a poorer quality of permeate water from the RO.

Please note:

The use of various chemical additives are controlled under regulatory standards.

Compact Reverse Osmosis System:

The RO-Compact uses reverse osmosis technology to reduce the total level of dissolved solids in a feed stream.

The system uses a spiral wound compact membrane for production of permeate water.

The permeate water from the system typically exhibits a 95% (or better) reduction of the total dissolved solids level (TDS) from the feed water.

The reject, or concentrate water contains minerals that have not been permitted to pass through the membrane. The RO-Compact also features a permeate flush.

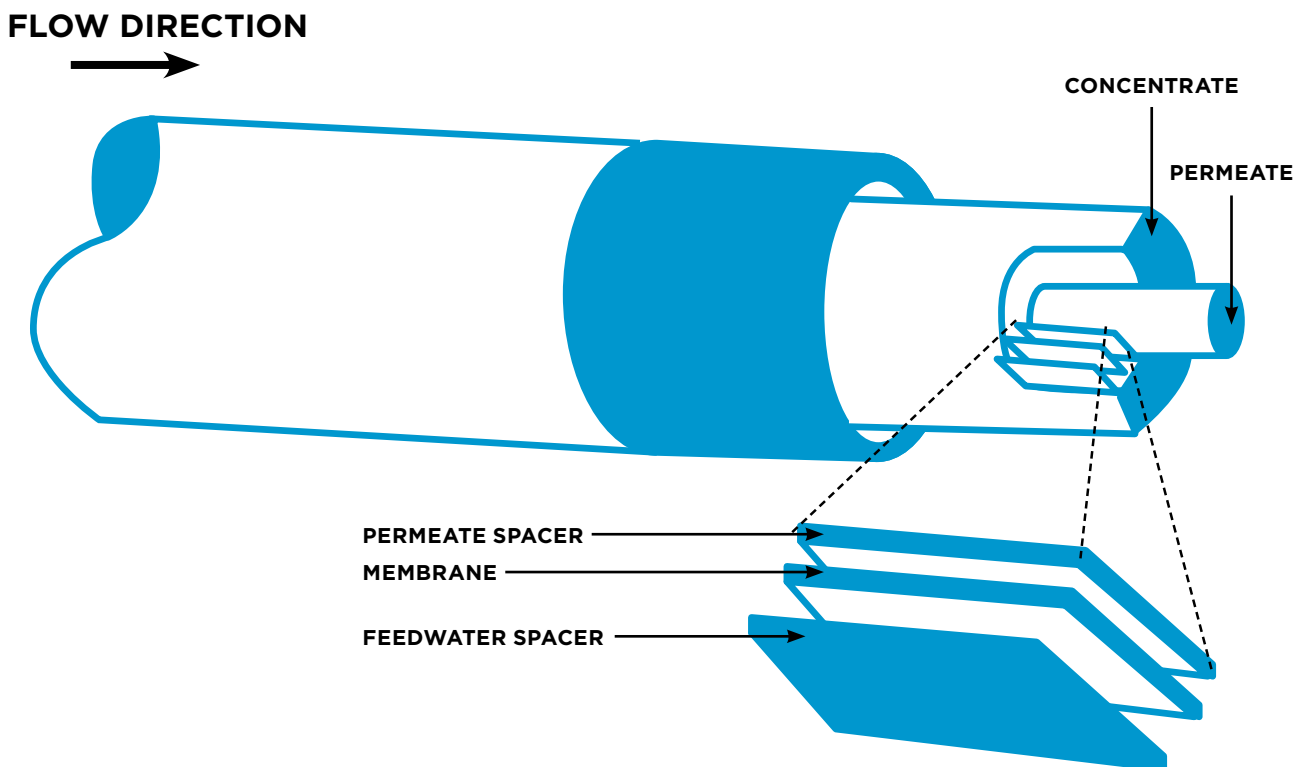

Operating Conditions

The following operating parameters detail the optimum conditions for peak performance of the Kinetico RO-Compact Range.

If there are parameters that you are concerned about, please contact your local Kinetico Representative.



Exceeding the stated specifications may inhibit the performance or cause the system to be permanently damaged.

To ensure the conditions are met, annual water analysis is recommended to keep track of your water quality. This will indicate any changes in your inlet water supply.

If the inlet supply does change, please contact your Kinetico Representative for advice.

Modifications to the system or additional equipment may be required to maintain peak operation efficiency.

Model:	RO-Compact 1	RO-Compact 2	RO-Compact 3
Unit			
Dimensions d x w x h/mm	560 x 250 x 760	580 x 460 x 700	580 x 460 x 700
Minimum Production Rate 15°C Litres/hour	160	300	420
Minimum Inlet Flow Rate 15°C Litres/minute	6,7 40% 4,44 50% 2,96 75%	10 50% 5,91 75%	14 50% 8,87 75%
Membrane Type	Thin Film Low 3	Thin Film Low 3	Thin Film Low 3
Number of Membranes	1	2	3
Rejection Rate Typical	97% - 98,5%	97% - 98,5%	97% - 98,5%
Recovery Ratio 0° dh	75%	75%	75%
Recovery Ratio 10° dh	50%	50%	50%
Recovery Ratio 25° dh	40%	---	---
Inlet Pump Type	Brass rotary vane	Brass rotary vane	Brass rotary vane
Inlet Motor watts	560	560	1120
Inlet Feed Valve	solenoid valve	solenoid valve	solenoid valve
Delivery Pump	multi-stage 500 watts	multi-stage 500 watts	multi-stage 500 watts
Power volts	230	230	230
Frequency hertz	50	50	50
Power kW	1,1	1,1	1,7
Feed Water			
Pressure bar	1 - 7	1 - 7	1 - 7
Temperature °C	5 - max 25	5 - max 25	5 - max 25
pH	3 - 10	3 - 10	3 - 10
Hardness (max.) °dH	25	10	10
Iron (max.) PPM as Fe	0.2	0.2	0.2
Chlorine (max.) PPM as	< 0,1	0,05	0,05
Total Dissolved Solids (max.) PPL as NaCl	1,500	1,500	1,500
Operating Pressure bar	9 - 14	9 - 14	9 - 14
Product Water Storage Tank	atmospheric	atmospheric	atmospheric
Fitting Connections			
Inlet diameter	3/4" BPS SS	3/4" BPS N.B	3/4" BPS N.B
Permeate diameter	3/4" BPS SS	3/4" BPS N.B	3/4" BPS N.B
Drain diameter	10 mm Push-in	10 mm Push-in	10 mm Push-in

The Components

The following components are used in the RO-Compact series.

1 Inlet:

The connection is a stainless steel, 3/4" BPS male nipple.

2 Outlet:

The connection is a 3/4" BSP male nipple. Permeate line from the TC RO should be made with stainless steel or plastic.

3 Permeate Reservoir:

A 35 / 66 litres polypropylene container is used to store permeate water. The material is ideal for the storage of reverse osmosis quality water.

4 Delivery Pump:

A multi-stage centrifugal pump. This pump will pressurise the permeate water to 3 bar, at a flow rate of 1200 l/h.

5 Non-Return Valve:

Located after the distribution pump, it prohibits water from back-flowing into the permeate reservoir.

6 Reservoir Overflow Connection:

A 1/2"(C1) 1"(C2,C3) tubing connection is to be made to drain. This drain is a safety for the overflow of the permeate reservoir.

7 Electrical Connection:

A (1.5 mm²) cable is supplied with the unit. The

cable must be attached to an approved electrical connector (plug).

Supply Power Required: 230 VAC, 1 Phase, 50 Hz.

8 Drain (Reject) Connection:

A 10mm push style connection is used to make the drain connection.

Do not restrict the drain connection, as this could result in the building of pressure in excess of 15 bar.

9 Feed Solenoid Valve:

A brass, normally closed (NC) solenoid valve is used to shut flow off to the system during shutdown conditions.

10 Non-Return Valve:

An in-line non-return valve is used to prevent back-flow from the system.

11 Inlet Pump:

The rotary vane pressurization pump provides pressure to the RO-Compact series as required for proper operation.

The motor used with this pump is of TEFC construction.

The fan also provides air circulation within the top cover of the cabinet, helping to regulate the temperature of the electronics. The pump is design to deliver 1,000 l/h at 12 bar pressure.

12 Low Pressure Switch:

The low pressure switch is used to shut the system down if an inadequate feed pressure is present.

The set point for the pressure switch is 1 bar. The switch is located between the inlet valve and pump.

13 By-Pass Solenoid Valve:

Another exclusive feature of the RO-Compact series is an automatic by-pass valve. As a normally open valve, the valve allows inlet water to be bypassed should the permeate reservoir become exhausted.

This assures the operator equipment or process will not be damaged by a lack of water. Provided there is water in the permeate tank, the by-pass valve instantly closes as soon as the flow switch is activated by the need for water. (This valve is not included with the "U" versions of these systems.

These units have no bypass. A pressure switch is substituted for the bypass to signal the operation of the pressurization pump.)

14 Non-Return Valve:

This nickel plated valve prohibits permeate water from back flowing to the inlet tap.

15 Flow Switch:

This electric contact has a sensitivity to activate at 1 l/m.

At this contact, the unit shuts the bypass valve, provided there is water in the permeate reservoir, and activates the distribution pump.

Fittings:

The following fittings are used in the RO-Compact Series.

(Despite appearances, they have the same part number and function in the same way.)

Part 170451:



Part 170449:



Part 170448:



Part 170463:



Part 521122:



RO Compact 1:

See pages 12 - 13 for component descriptions.

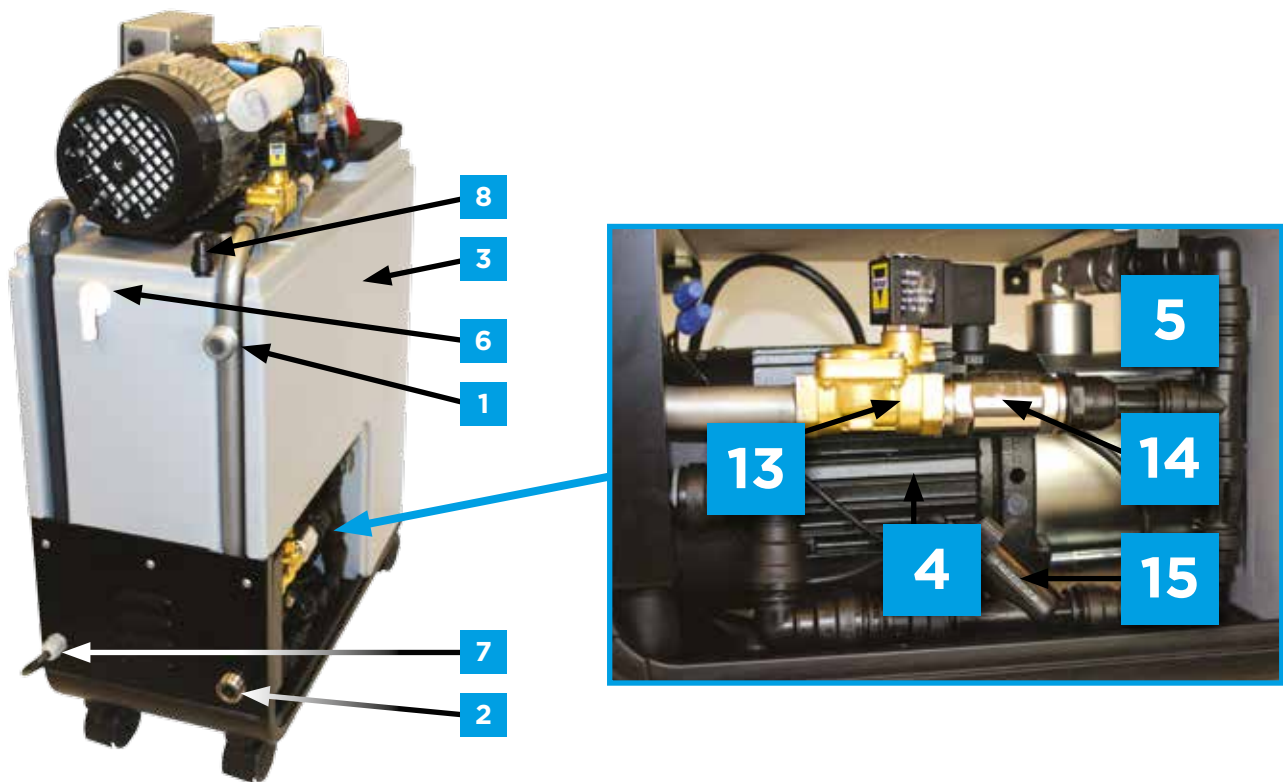

Close Up:

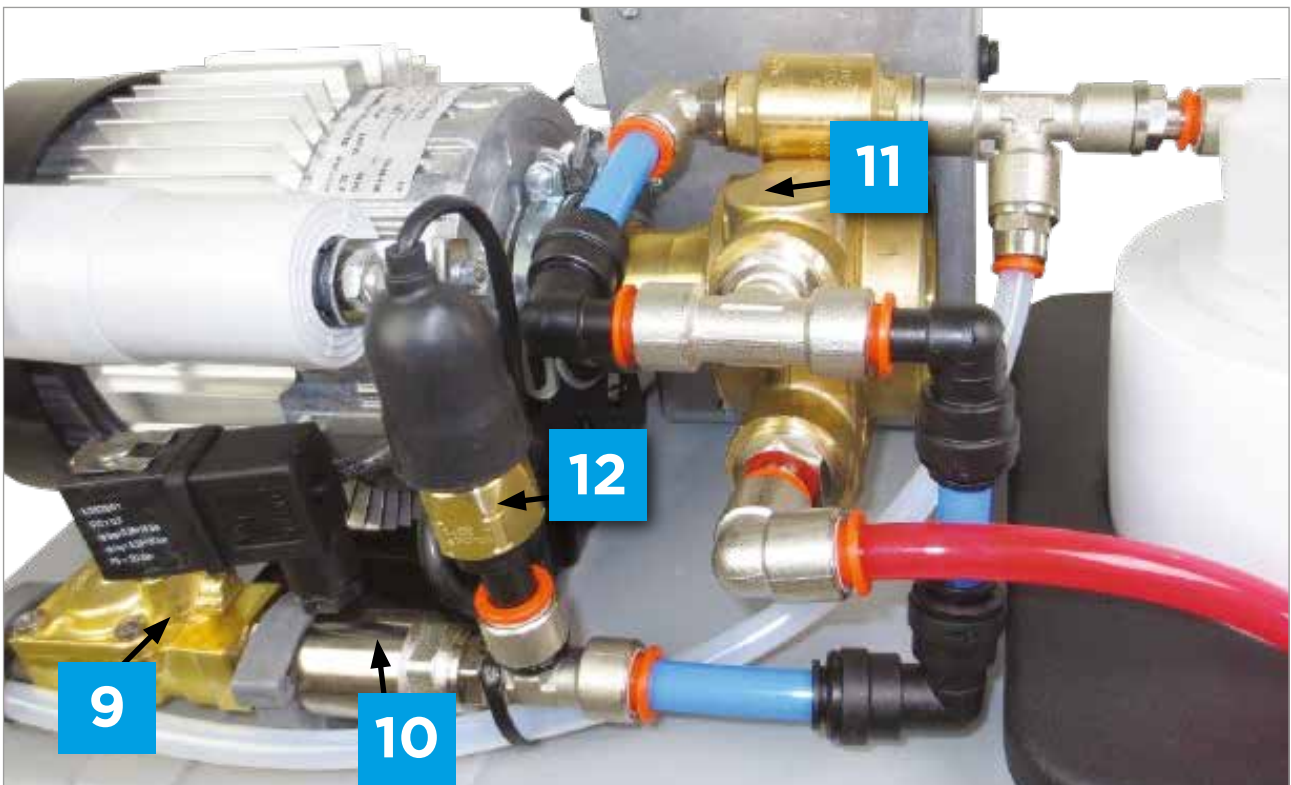

RO Compact 2:

See pages 12 - 13 for component descriptions.

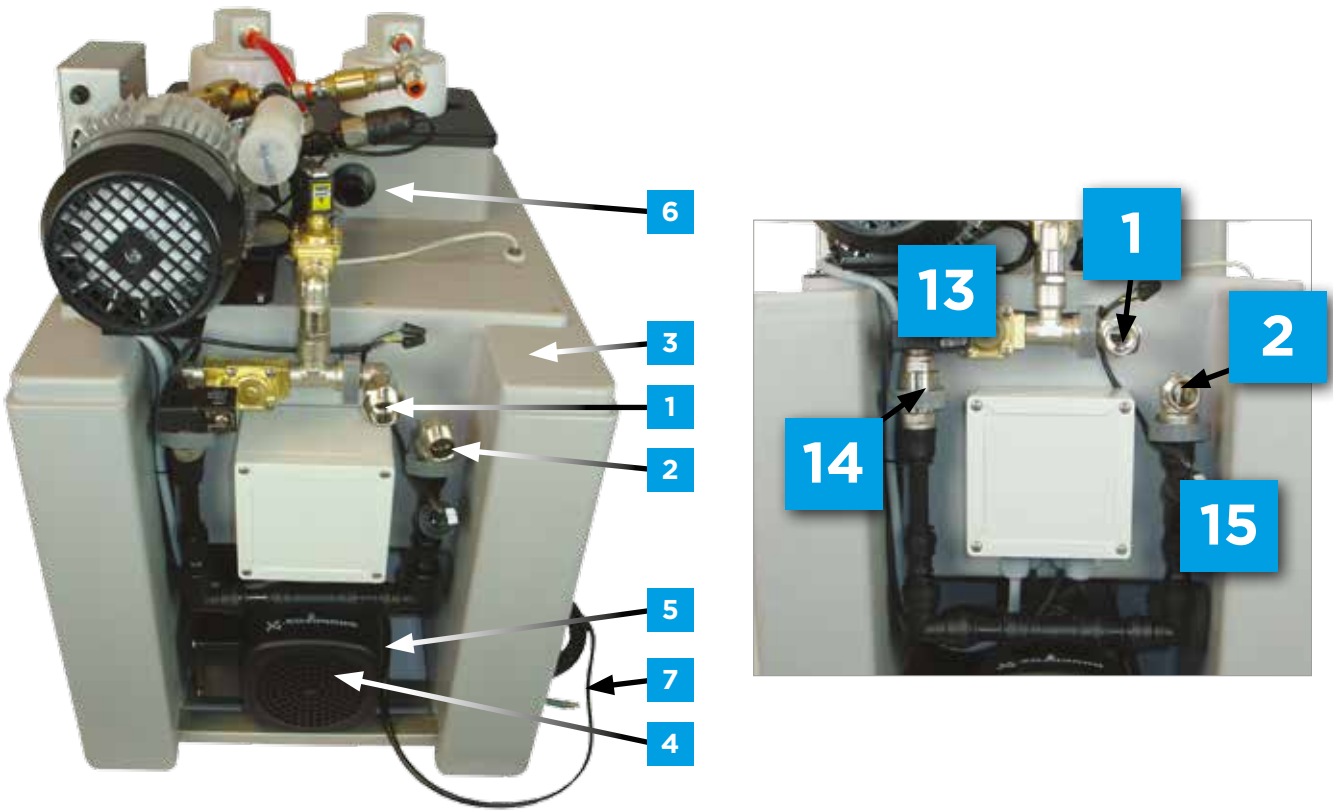

Close Up:

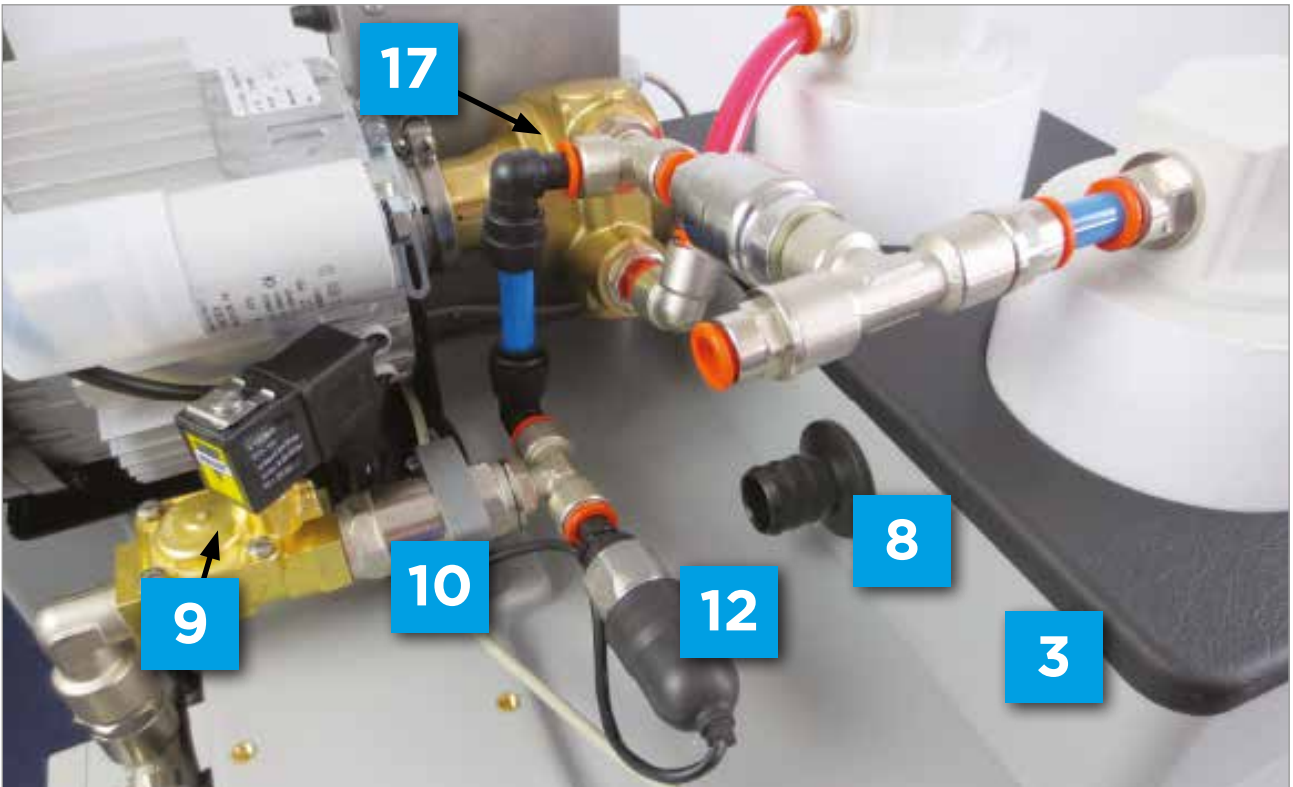

RO Compact 3:

See pages 12 - 13 for component descriptions.

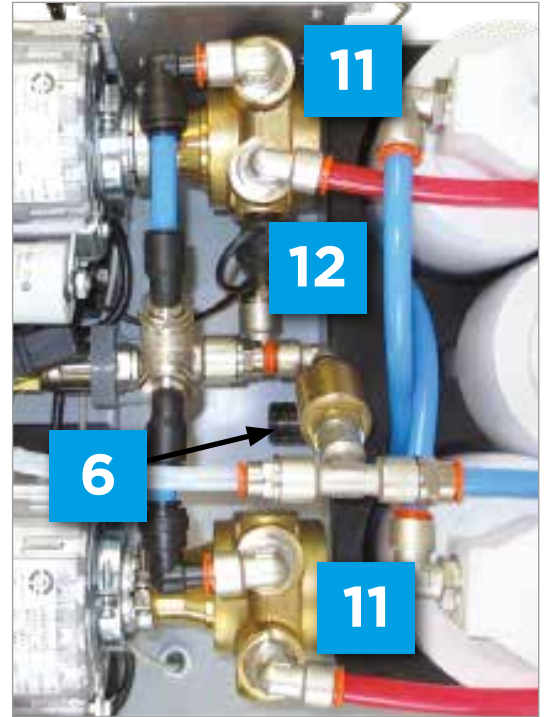
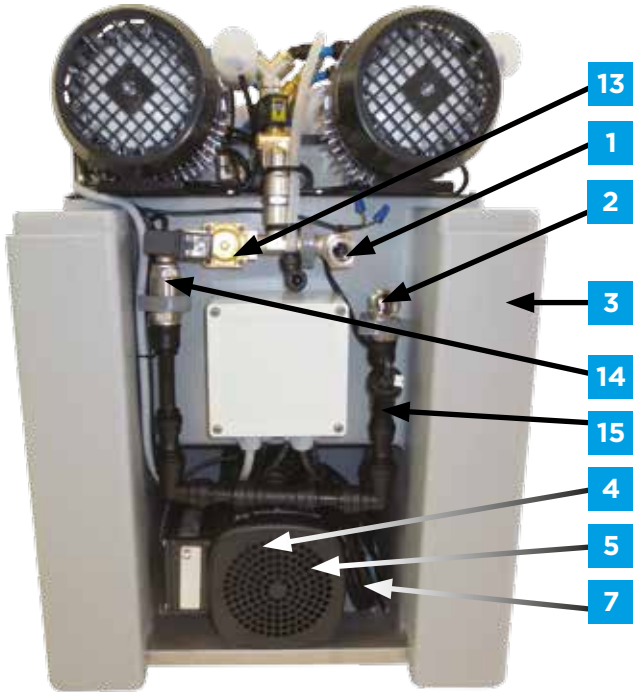

Close Up:

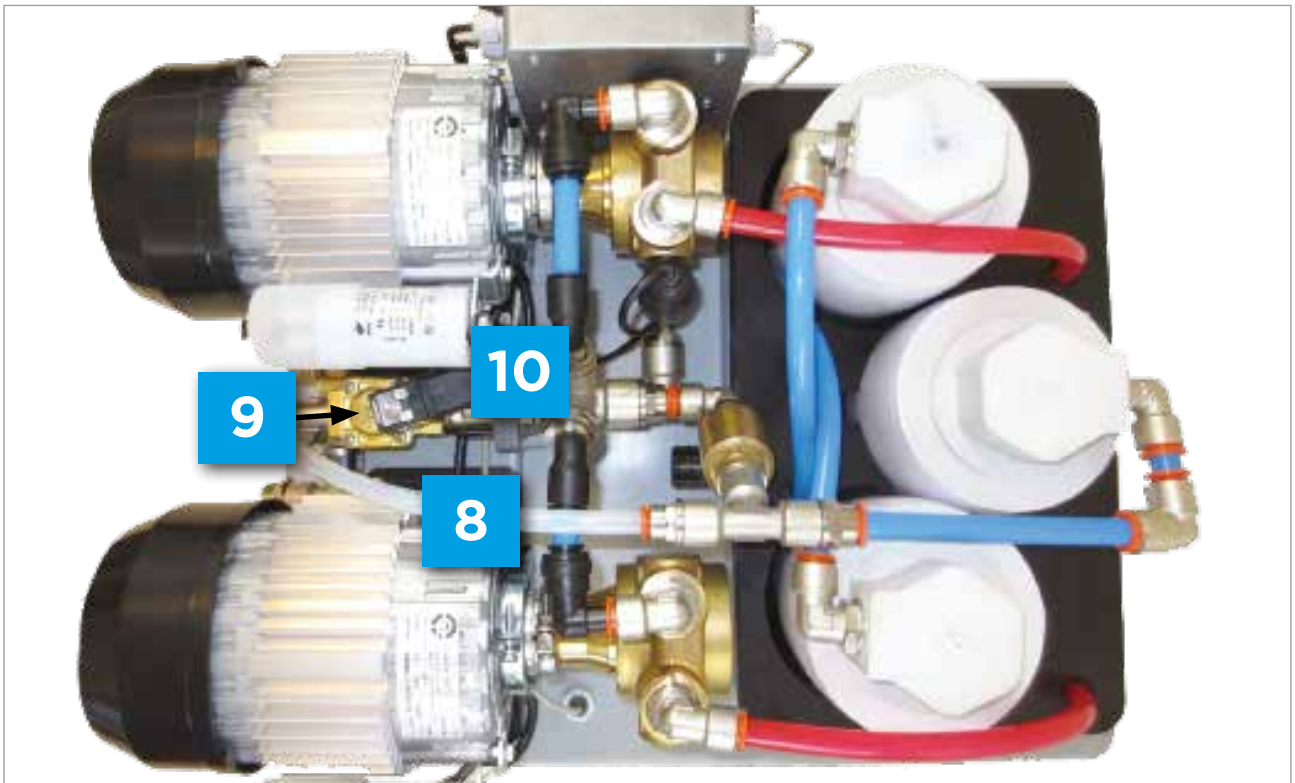

Level Switch:

A level Switch is built into the permeate reservoir.

The mid and high level switches are used to measure permeate volume. With a set distance between these floats, the circuit board is designed to time the refill between these two points, and display the calculated batch flow rate.



System Controller:

The Compact Series is operated by a microprocessor controller, designed to enhance the operation of the system when operating with dishwasher machines.

Each input is a low voltage signal processed internally by the controller. Each output is processed at 230 VAC, and controlled by the system's input. All of this adds to the safety of the system's operation.

The following components are operated by the controller:

- Inlet Pump
- Inlet Solenoid Valve
- By-pass Solenoid Valve
- Distribution Pump

Please note: The control Box has no serviceable components and should not be opened, unless by a trained electrician.

Permeate Flow Rate

The permeate flow rate will be displayed after the completion of each batch cycle (when the unit refills with water between the mid and high levels, without calling for water). Three dashes will be displayed (- - -), when the refill cycle is interrupted by the distribution pump calling for water.

Power

A number or three dashes, will indicate when power is energized to the system.

Membrane Alarm

The Membrane Alarm "ERR" will activate if a product cycle is lower than the alarm set point. It will flash if the production cycle is above the alarm set point. In each case, service is recommended.

No Water Alarm

The No Water Alarm will activate when feed pressure to the system is below minimum. It will flash when the cabinet is empty.



Installation

The following process has been developed to assist you with the installation of your RO-Compact product.



The installation of this RO should be performed by a qualified service person with an understanding of local and regional codes that may affect the installation requirements.

Pre-Installation Review:

Before beginning the installation of the RO-Compact, determine the system configuration to be installed and components that have been ordered. Please refer to the RO-Compact series system specification sheet which will specify the required components.

A thorough review of the customer's facilities is also recommended. Pay particular attention to the critical operating data which could affect the operation of the system.

Water Pressure:



Water pressure to the RO-Compact system has an effect on the maximum flow through the system. The system will not operate if the inlet pressure fluctuates below a dynamic pressure of 1 bar.



This minimum pressure must be maintained to the system at all times. Should the pressure fluctuate below this level, a booster pump may be required.

Temperature:



The ambient temperature must be maintained above 2°C.

Freezing temperatures will cause damage to the equipment and void all warranties.



Inlet water temperature must be maintained between 5°C and 25°C.

This is necessary to prevent damage to the system's membrane.

System Location:



The unit must be installed indoors.

Failure to comply with this requirement can cause significant damage to the system and will create a safety concern.

The unit must be placed on a frost-free, even surface.

The floor must be able to withstand the load of the system when filled with water:

76 kg RO-Compact 1

125 kg RO-Compact 2

138 kg RO-Compact 3



The unit must be installed in a room with open floor drains.



Do not block ventilation grids at base of system.

Electrical Connection:



Electrical connection must be made in accordance with local regulations.

Unpacking:

1. Release the box from the pallet.
2. Lift the box from the pallet. It will slide straight up and uncover the RO-Compact.
3. Discard packing material and set aside the additional 2 meters of 10 mm tubing system manual.
4. Inspect the unit for possible shipping damage. Including cabinet damage, broken fittings, dents or scratches.

Cabinet Positioning:

The RO-Compact series has been specifically designed to be moved and positioned conveniently under a standard level counter.



Caution should be used whenever moving the equipment.

Move the RO cabinet to the location of the installation.

You must take into consideration that the hood can be removed for easy access. Either a height clearance of 25cm must be left or it must be made possible that the unit can be pulled out for servicing.

Colour codes on the wires:

The unit must be connected to positive + neutral + ground.

Blue wire: Neutral

Brown wire: Positive

Yellow/green wire: Ground

RO-Compact 1	
Dimensions d x w x h/cm	55 x 25 x 76
Required Clearance for Removing Cover cm	101
Weight (dry) kg	43
Voltage Volts	230
Frequency Hz	50
Amperage Amps	10
Power kw	1,1

RO-Compact 2	
Dimensions d x w x h/cm	58 x 46 x 70
Required Clearance for Removing Cover cm	88
Weight (dry) kg	56
Voltage Volts	230
Frequency Hz	50
Amperage Amps	10
Power kw	1,1

RO-Compact 3	
Dimensions d x w x h/cm	58 x 46 x 70
Required Clearance for Removing Cover cm	88
Weight (dry) kg	71
Voltage Volts	230
Frequency Hz	50
Amperage Amps	10
Power kw	1,7

Plumbing Connections

The following connections are used throughout the RO-Compact series.

1 Inlet Connection:



Make sure that the inlet screen is in place.

Connect the feed water line to the inlet of the RO. This requires a 3/4" BSP connection. On the inlet a ball valve with handle must be installed. This is used to shut-off the raw water when servicing the unit. The pipe size must be minimum 1/2".

This will ensure the necessary pressure and flow to the unit at all time. The use of an additional 1.5m of flexible material is recommended to allow for movement of the cabinet system.



Inlet Screen

2 Permeate Connection:

Remove the shipping cap from the system. Connect the permeate water line using a 3/4" BSP connection. The use of an additional 1.5m of flexible material is recommended to allow for movement of the cabinet system. The Permeate connection must be completed in a material suitable for the handling of reverse osmosis water (stainless steel or plastic.)

3 Drain Connection:



Using the supplied 10mm flexible tubing, connect to the push fitting and run to a suitable drain. The tube must be pressed fully into the connection. Make sure that afterwards you cannot pull it out without releasing the locking. The open end is connected to an open floor drain. Do not submerge the end of the tube into the drain water. This creates a risk of siphoning when the unit is in standstill. Do not apply back pressure the drain line.

Do not bend the drain tube at any time.

4 Permeate Reservoir Overflow:

Use a 1/2" tube to the Compact1, and a 1" tube to the compact 2 and 3 connect the overflow tubing to a suitable drain. This is a system safety and the connection should be made as a part of a proper installation.

5 Electrical Hook-up:

After installing the skid connections, bring power to the RO-compact.

RO Compact 1:

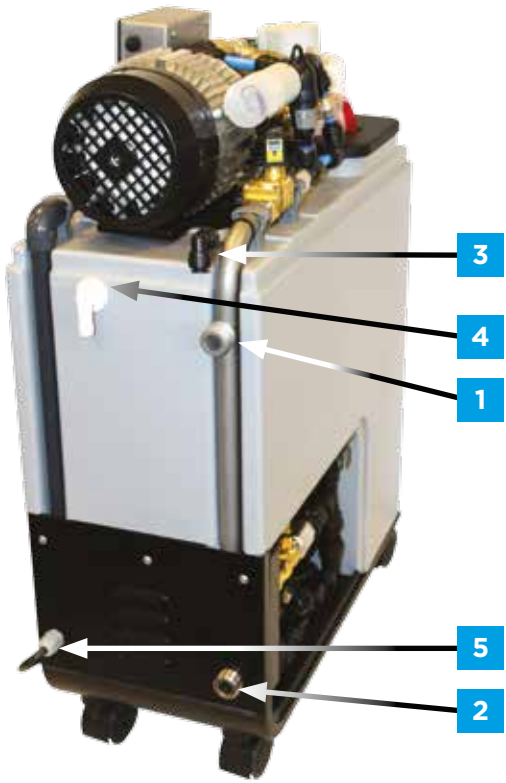

RO Compact 2:

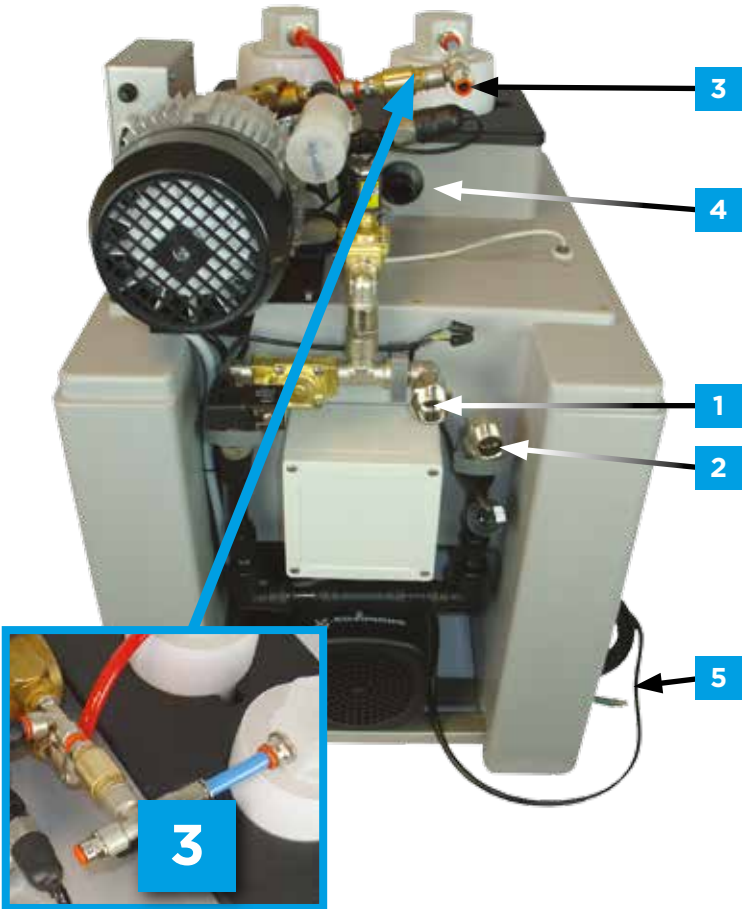

RO Compact 3:

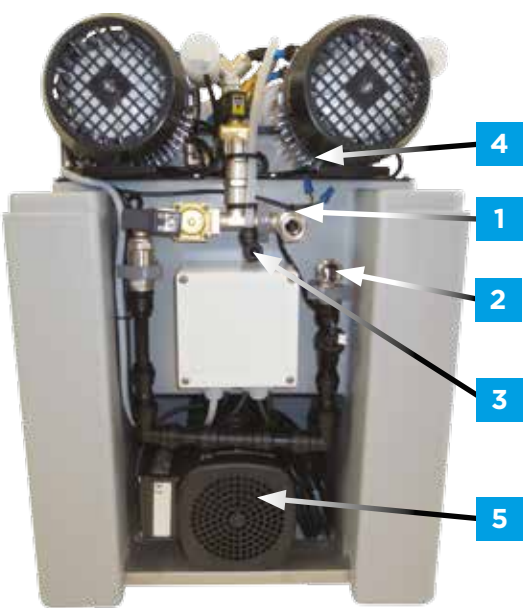

Operation and Maintenance

A definition of terms for the system operation inputs and outputs.

Key:

NO = Normally Open NC = Normally Closed

Inputs:

Inlet Pressure Switch (NO)	PS1
Flow Switch (NO)	FS1
Pressure Switch (NC)	PS2
High Level Float Switch (NO)	LSH
Mid Level Float Switch (NO)	LSM
Low Level Float Switch (NO)	LSL
System Switch (On/Off)	SW1
RO Production Level Jumper (J1)	J1
System Selection Jumper (J2 & J3)	J2, J3

Outputs:

Feed Solenoid Valve (NC) (230Vac 50Hz)	MV1
Bypass Solenoid Valve (NO) (230Vac 50Hz)	MV2
High Pressure Feed Pump (230Vac 50Hz)	P1
Distribution Pump (230Vac 50Hz)	P2
No Water" Alarm Indicator Lamp	IND2
"Change Membrane" Alarm Indicator Lamp	IND3
High Pressure Feed Pump (P1) Run Lamp	LMP1
Feed Solenoid (Mv1)Valve Lamp	LMP2
Distribution Pump	
Bypass Valve (P2-Mv2) Lamp	LMP3
Display Screen	SCRN
Alarm Contact (Dry Contact)	AUX

Definition of terms:

Inlet Pressure Switch - PS1

(Normally Open)

A normally open (NO) contact pressure switch with a set point of 1 bar (14.5 psi) is located on the feed water inlet. Below 1 bar the contact is Open, not allowing power to flow through the device. Above 1 bar the contact is closed, allowing power to flow through the device.

High Level Float Switch - LSH

(Normally Open)

A normally open (NO) contact float switch located in the RO permeate reservoir, above the mid level float near the top of the reservoir. Below this level the contact is open, not allowing power to flow through the device. Above this level the contact is closed, allowing power to flow through the device.

Mid Level Float Switch - LSM

(Normally Open)

A normally open (NO) contact float switch located in the RO permeate reservoir below the high level float in the middle of the reservoir. Below this level the contact is open, not allowing power to flow through the device. Above this level the contact is closed, allowing power to flow through the device.

Low Level Float Switch - LSL

(Normally Open)

A normally open (NO) contact float switch located in the RO permeate reservoir below the mid level float near the bottom of the reservoir. Below this level the contact is open, not allowing

power to flow through the device. Above this level the contact is closed, allowing power to flow through the device.

Flow Switch - FS1

(Normally Open)

A normally open (NO) contact flow switch located on the permeate outlet to the users equipment.

Bypass Solenoid Valve - MV2

(Normally Open)

This is a normally open (NO) 230VAC, 50/60 Hz solenoid located on the line between the feed water inlet connection and the permeate water outlet connections. When energized with power, the solenoid closes.

Feed Solenoid Valve - MV1

(Normally Closed)

This is a normally closed (NC) 230VAC, 50/60 Hz solenoid located on the line between the feed water inlet and high pressure feed pump. When energized with power, the solenoid valve opens.

High Pressure Feed Pump - P1

This is a 230VAC, 560W, 50 Hz, 4.2A single phase rotary vane pump used to pressurize the water from the feed water inlet connection to the RO membrane.

Distribution Pump - P2

This pump is a 230VAC, 500W, 50Hz, 2.9A single phase centrifugal pump, used to depressurise the permeate water in the permeate reservoir and send it to the permeate outlet connection.

Feed Water Inlet Connection

This is the connection from the users feed water supply line. This line is connected to the bypass solenoid.

Permeate Outlet Connection

This is the connection to the users equipment. When RO water is available, it is pressurized by the RO Permeate Pump. If water is not available, Inlet feed water is provided bypass solenoid valve.

Permeate Reservoir

This is the sump which houses the three float switches, high level, mid level and low level floats. Permeate water generated by the RO membrane is stored in this sump for use by the user.

System Switch - SW1

This is a switch located on the outside of the IP65 electrical box.

RO Production Level Jumper - J1

This is a jumper located on the inside of the electrical enclosure on the circuit board itself. If the jumper is made across the contacts then the logic will use the high level float as the point to begin making RO water to fill the RO Permeate Reservoir. If the jumper is not made across the contacts then the logic will use the mid level float as the point to begin making RO water to fill the RO Permeate Reservoir.

System Selection Jumper - J2 & J3

These are two jumpers located on the inside of the electrical enclosure, on the circuit board itself. There are 4 system varieties. Each system has a different minimum and maximum RO production set point for the change membrane alarm and a different volume setting used in the calculation of RO production rate. This allows for the greater systems to have a larger volume between the mid and high level compensating for the larger RO permeate reservoirs. It also enables a set distance between the high and mid float for standardisation.

RO-Compact 1

J2 and J3	0 + 0
Volume Litres	9,1
Min Value L/ph	100
Max Value L/ph	350

RO-Compact 2

J2 and J3	0 + 1
Volume Litres	18,2
Min Value L/ph	133
Max Value L/ph	470

RO-Compact 3

J2 and J3	1 + 0
Volume Litres	17,4
Min Value L/ph	280
Max Value L/ph	820

High Pressure Feed Pump - LMP1

Run Lamp

A lamp located on the circuit board to denote when the high pressure feed pump (P1) is energized.

Feed Solenoid Valve Lamp - LMP2

A lamp located on the circuit board to denote when the feed solenoid valve (MV1) is energized.

Distribution Pump/Bypass - LMP3

Valve Lamp

A lamp located on the circuit board to denote when the distribution pump (P2) and bypass valve (MV2) are energized.

“No Water” Alarm Indicator - IND2

Lamp (Red)

A lamp located on the front of the enclosure, to denote the inlet pressure condition is low. If the lamp flashes it means there is no water in the reservoir.

“Change Membrane” Alarm - IND3

Indicator Lamp (Yellow)

A lamp located on the front of the enclosure, to denote the calculation made by the production of RO water between the mid level and high level is outside of the minimum and maximum set points. If the production rate in l/ph is below a minimum setting, the indicator lamp (IND3) will be on constantly. If the production rate in l/ph is above a maximum setting the indicator lamp (IND3) will flash.

Display Screen - SCR1

A 3 digit display denotes the l/ph of water produced by the RO Membranes (RO permeate rate). This value is calculated by using a set volume based on jumpers J2 and J3, and the time it takes to fill the RO Permeate Reservoir between the mid level and high level. The distribution pump P2 must not be on during this calculation time. This calculated value is compared with a minimum and maximum value to initiate a “change membrane” alarm as described by IND3.

External Alarm Contact - CR1

This is a 5 amp relay contact with a common, normally open contact. This can be used as a dry contact closure for either the “No Water” alarm or the “Change Membrane” alarm. If either of these indicator lights are energized, then this relay is also energized.

Outlet Pressure Switch - PS2

(Normally Closed)

A normally closed (NC) contact pressure switch with a set point of 1.6 bar (36.25 psi) located on the permeate water outlet. Below 1.6 bar the contact is closed, allowing power to flow through the device. Above 1.6 bar the contact is open, not allowing power to flow through the device. This device is used on no-bypass systems and is wired in parallel with the flow switch FS1.

Using the RO-Compact System

A guide to using and maintaining the RO-Compact system.



The system requires, therefore ensure it is switched on prior to intended use.

Producing RO water:

RO permeate water is produced through the RO membrane. The RO permeate reservoir is filled when the water level is either below the high level (J1 triggers high level and distribution pump turns on) or below the mid level (J1 picks mid level and distribution pump turns on).

When RO water is in use, the unit should be turned on to maintain the appropriate level of RO permeate water in the RO permeate reservoir.

Water is also produced when the level is below the low level in the RO permeate reservoir. This occurs primarily at start up. It is important to note that the water level in the permeate reservoir will drop below the high level at shut off. This is due to the flushing of the membrane, located in the RO Permeate water reservoir.

The high pressure feed pump is directly linked to the feed solenoid operation and will turn on 6 seconds after the feed solenoid valve is opened. This ensures that water is available to the pump prior to turning on.

The feed solenoid valve will remain open until the tank has filled up to above the high level, or until the system is turned off.

The high pressure feed pump will turn off when the feed solenoid valve is closed.



The high pressure feed pump is protected by the inlet pressure switch. If inlet water pressure is low, or below the 1 bar set point it will turn off. It will

remain off until the inlet pressure has returned to above the 1 bar set point (assuming that the feed solenoid valve is still open).

During times of low inlet pressure, only the high pressure feed pump turns off. The feed solenoid valve will remain open.

Therefore, the RO membrane can still permeate a small amount of RO permeate using line pressure. There is a time delay of 5 seconds on the inlet pressure switch as described in other sections.

Please note:

The membrane clogs faster, when circulation is lacking.

Supplying RO water:

RO water is supplied to the user via the distribution pump and bypass solenoid valve. When the use of water begins, the bypass solenoid valve remains closed and allows inlet water to flow through the RO permeate outlet connection. This flow also trips the flow switch.

If the flow switch is tripped when the water level is above the low level in the reservoir, the distribution pump is turned on, and the bypass solenoid valve is opened, shutting the bypass line.

At this point, RO permeate water from the RO permeate reservoir is pumped out to the user, instead of the bypassed inlet water. This

condition continues until either the water in the sump drops below the low level of the permeate reservoir or the water is turned off and the flow switch senses no flow. When these situations occur, the RO permeate pump will shut off after a 5 second delay and the bypass solenoid valve will open allowing inlet water to bypass the RO and flow directly out through the permeate connection.

The RO permeate pump is directly controlled by the flow switch and the low level float.

As soon as flow is sensed by the flow switch, the RO permeate pump will turn on (assuming the water is above the low level). Following this, when the flow switch once again senses no flow, there will be a 5 second delay before the RO permeate pump shuts off.

If during this time the water level drops below the low level float, the RO permeate pump will immediately shut off.

The pump will turn back on again when the water level has returned above the low level float and the flow switch senses flow.

Non-bypass systems:

In the case of non-bypass systems, the bypass line will be shut off, the bypass solenoid removed and an extra normally closed (NC) pressure switch will be wired in parallel with the flow switch input.

In this instance, when the user opens the permeate line to use water, pressure is relieved in the line, and the distribution pump is turned on.

Pressure is re-established in the line during this process, but the flow switch keeps the pump running until the line is closed by the user's device.

Please note:

The pump will remain running for 5 seconds and then shut off due to no flow.

This delay is critical to the no-bypass system as there may be a few seconds between the NC pressure switch triggering the pump to turn on and the flow switch triggering the pump to remain running. The 5 second delay also prevents the pump from mistakenly shutting off due to bouncing switches or momentary loss of contact in flow and pressure switches.

The device display will indicate the RO production rate. If desired, the circuit board will also operate without the display.

Daily start-up/shutdown:

The equipment will run in an automatic mode, shutting itself off each time the high level is reached in the RO permeate reservoir. As part of this the automatic control, the pump will shut off and a permeate flush will occur. This rinse flushes the membrane with permeate water, minimizing the possibility of membrane fouling.

Daily log:

A daily log can be found at the back of this manual. It is recommended that this page is photocopied and used to record the performance of the system on a daily basis. Recording these characteristics every day will help to solve any problems that may arise in the future. E.g. A change in the performance may be recorded indicating possible fouling of the membrane.

Accurate logging and timely membrane cleaning will help to ensure maximum membrane life.

Routine Maintenance

Filter maintenance:

The system will shut down if the feed pressure is too low (not above 1 bar). In this situation, it is likely that the filter cartridge will need to be replaced. Refer to the daily log for changes in the inlet pressure.

We recommend replacing the filter cartridge when the pre-filter pressure drops to ½ bar.

Membrane cleaning:

It is possible to establish the need for membrane cleaning when referring to the daily log. If the cycle time of the system has decreased by more than 50%, the membrane may require cleaning. Please refer to the maintenance section of this manual for further details.

Long Term System Shutdowns:

If the system is to be out of operation for more than 30 days:

- Allow the system to completely fill the RO permeate reservoir and perform a permeate flush.
- Shut the system switch off and disconnect the power.
- Disconnect the permeate line.



Mix a volume of 1% sodium bisulfite (by weight) into the permeate reservoir - 35 litre capacity. (Note: sodium bisulfite should be food grade, not cobalt activated).

Long term start-ups:

This procedure should be completed after the unit has been sanitized with sodium bisulfite.

- 1 Temporarily connect the permeate outlet to the drain with ½" hose.
- 2 Turn the power to the unit on.
- 3 Turn the RO system on.
- 4 Open the permeate line and allow the permeate tank to empty completely.
- 5 Allow the water to run for 15 minutes, this will activate a fill cycle for the system.
- 6 After 15 minutes, shut the unit down, reconnect the permeate line, then begin normal operation.

Troubleshooting

Why is the control power light off?

- 1. The incoming power was interrupted**
Ensure the incoming branch circuit is on.

Why won't the inlet pump start?

- 1. The thermal protection tripped on the motor**
Disconnect power from the unit, wait for 30 minutes, then try to restart system.
- 2. The system is switched is off**
Make sure the system switch is in the on position.
- 3. The system does not need to produce water**
If the tank is full, the system will not need to produce water. Make sure the system float is in the down position, and water has been required by from using the flow switch.

The time delay for the pump to start is 7 seconds after the inlet solenoid valve opens.
- 4. High level float is incorrect**
The system will begin running with an open contact from the high level float and a signal from the flow switch.

Check the wiring and continuity of the high level switch in the on and off position.

Why is the permeate tank overflowing?

- 1. There is a level float malfunction**
Check the operation of the high level float. The float should engage contact before the water level reaches the top of the tank.

2. Inlet solenoid valve is not shutting

Shut the system down. After the permeate flush cycle has finished, check the permeate line. Water should not be flowing past the inlet solenoid valve. Remove one of the push fittings after the inlet pump to check for flow.

Why is there poor permeate quality?

- 1. The inlet TDS is too high**
Check the inlet TDS. The Compact Series is designed to operate with a 98% rejection.

The maximum inlet TDS for the system is 2,500 mg/l as NaCl. Feed water with a quality over 1,000 mg/l may produce TDS too high for spot free rinsing.
- 2. The permeate flush is not operating**
Cycle the system through permeate flush, check to make sure the water continues to run to drain after the inlet valve and pump are shut off.

This can be checked by disconnecting the reject push fitting. Approximately 3 litres of water should flow before the flush is complete.
- 3. There is chlorine damage to the membrane**
Check the inlet chlorine levels, residual less than 0.05 mg/l is required to prevent a thin film composite membrane deterioration.

Why does the system not run consistently?

1. Low pressure alarm

Feed pressure is too low - Check the inlet pressure while the system is running. System will shutdown if feed pressure is below 1 bar.

Check the cartridge filter - replace if the pressure loss exceeds 0.5 bar.

System leak - check and repair.

2. Low permeate flow

Water temperature is low or the membrane is fouled.

3. Membrane fouled

Check the system log for history, if a consistent decline in production is found, clean the membrane. Contact Kinetico for the appropriate cleaning procedure and chemicals.

4. Confirm system operating parameters.

5. Float switches are not operating properly

Check the operation of level switches.

Why is frequent membrane cleaning required?

1. Recovery too high

Depending upon the water chemistry, a 50% system recovery is recommended as a maximum. For source water high in silt, hardness, silica or organics, a reduced recovery of 35% is recommended.

2. Ineffective cleaning solution

Silica treatment requires caustic cleaners heated to 40°C for maximum effectiveness. Hardness contamination is cleaned with acidic solutions.

3. Ineffective cleaning procedure

Temperature, flow rate, contact time and the chemicals used must be taken into consideration to prevent poor cleaning of the membrane. Contact Kinetico for further advice.

4. Damaged membrane

Replace the membrane.

Why is the production volume slow?

1. The system is not operating within the required specifications

Confirm the system operating parameters. The system should run at the stated permeate, recycle and reject flow rates.

2. Cold temperature

Inlet temperature is less than 10°C.

3. Fouled membrane

Check the permeate quality.

4. Low pump pressure

The RO-Compact series is designed to permeate a projected volume at a pump pressure of 9 - 12 bar and 15°C. Check if the pump pressure yields less than 9 bar.

5. Inlet quality changes

Analyse RO feed for chlorine, hardness and temperature.

Maintenance Timetable

The operating parameters should be tested if the performance of a system is a concern.

The performance of the TC RO system, depends upon the production rate.

Hours of Operation/Production	Item	Service Procedure
2,500 hours / 375,000 litres	Performance Test	Run a production test on the system
	Flow Restrictors	Clean or replace all of system flow restrictors
5,000 / 750,000 litres	Performance Test	Run a production test on the system
	Flow Restrictors	Clean or replace all system flow restrictors
7,500 / 1,125,000 litres	Performance Test	Run a production test on the system
	Flow Restrictors	Clean or replace all system flow restrictors
	Membrane	Replace membrane
10,000 / 1,500,000 litres	Performance Test	Run a production test on the system
	Flow Restrictors	Clean or replace all system flow restrictors
	Feed Pump	Replace feed pump head
	Feed Solenoid	Replace feed solenoid valve
	Process Solenoid	Replace process solenoid valve

Performance Test:

The performance of the RO-Compact 2 system, is dependent upon the production rate. This operating parameter should be tested whenever the performance of the system is a concern.

To check the production rate, follow the proceeding directions.

- 1 Start the unit and put it in a running mode.**
- 2 Empty the permeate reservoir.**
Empty it at least half way by opening the permeate line at the dishwasher.
- 3 As soon as the permeate line is opened, the permeate pump should turn on.**
- 4 Shut off the permeate line.**

The distribution pump will shut off after 5 seconds.

5 Wait for the feed pump to shut off.

At this point the display should indicate the batch flow rate of the system.

6 Depending on inlet water quality and temperature, permeate flow rate will vary.

System	RO 1	RO 2	RO 3
Batch Volume Litres	9,1	18,2	17,4
Min Value L/h	100	133	280
Typical Volume L/h	180	360	540

Solenoid Valve Maintenance

Each RO-compact unit has two solenoid valves which operate in opposite orientations. The feed solenoid valve normally closed and the process solenoid valve normally open.

Occasionally, debris may become trapped in the diaphragm of the valve, causing the valve to not close completely. To perform maintenance on the valve, use the following procedure:

1 Shut off the water

Unplug the system to prevent it from starting while you are working.

2 Unscrew the electrical connection to the solenoid valve.

3 Unplug the connector from the body of the valve



4 Unscrew the top of the valve



5 Remove the top portion of the valve



Be careful not to lose the pilot spring, located in the middle of the valve.

6 Remove the diaphragm



7 Clean the surface

Using a damp cloth or paper towel carefully clean the surface.



8 Replace the diaphragm and pilot spring

9 Re-fasten the top of the solenoid valve

10 Reconnect the power cable

Fasten using the screw provided.

11 Important! Clean or change the plunger to remove limescale build up



Feed Pump Maintenance

The feed pump uses a rotary vane pump to generate the required pressure.

Normal operation will cause wear to the pump head, leading to the eventual need for replacement of this component. To perform maintenance on the pump, use the following procedure:

1 Shut off the water

Unplug the system to prevent it from starting while you are working.

2



Remove the cover

3



Remove all flexible plumbing from the pump head

4



Remove quick connect fittings from the pump head

5



Uncouple the pump from the motor base

This is done by loosening the clamping ring.

6



Remove the old pump head

7



Replace the new pump head

Make sure the new pump head is properly greased prior to replacement.

8

When replacing the new pump head make sure the shaft and coupler are inline

This ensures the pump head is completely inserted into the old motor coupling.

9

Reconnect the clamp

Fasten with the screw provided.

Flow Restrictor Maintenance

Two flow restrictors are used with each RO-Compact unit. These restrictors have a fixed orifice and should be checked at least four times per year.

Blockage of the flow restrictor will change the operation of the membrane, and may cause rapid fouling of the system. To perform maintenance on these components use the following procedure:

RO-Compact 1:

1



Identify the reject and recirculation plumbing lines

4



Inspect for blockage

If an orifice is blocked, the fitting must be unscrewed before cleaning.

2



Remove the elbow and the check valve together with the drain line

5

Cleaning

Use water, or air pressure. Dilute acid may also be used should blockage be due to hardness scaling.

3



Disassemble the fittings

This will expose the fixed orifice flow restrictors.

6

Replace the fitting and elbow connectors

Note: Always check both orifices.

RO-Compact 2 and 3:

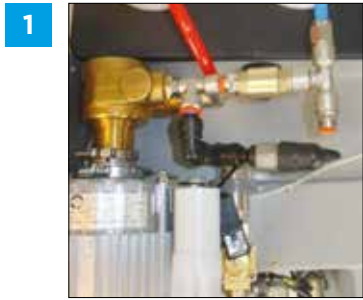

1 Identify the reject and recirculation plumbing lines



2 Remove the male and the check valve together with the drain line



3 Disassemble the fittings
This will expose the fixed orifice flow restrictors.

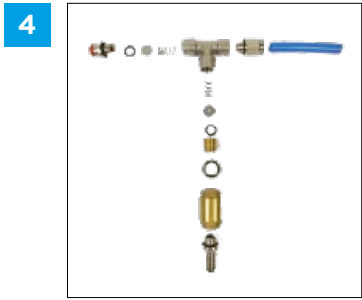

4 Inspect for blockage
If an orifice is blocked, the fitting must be unscrewed before cleaning.

Note: Always check both orifices.

5 Cleaning
Use water, or air pressure. Dilute acid may also be used should blockage be due to hardness scaling.

6 Replace the fitting and elbow connectors

Nozzle chart:

Model	Maximum Hardness O°dH	Recovery (%)	Circulation Nozzle	Permeate Nozzle	Setting
Compact 1	0	75	136	43	-
	10	50	115	67	-
	25	40	115	78	standard
Compact 2	0	75	115	43	standard
	10	50	115	89	-
	25	40	115	98	-
Compact 3	0	75	177	59	standard
	10	50	177	110	-

RO-Compact 1 Parts: The cabinet

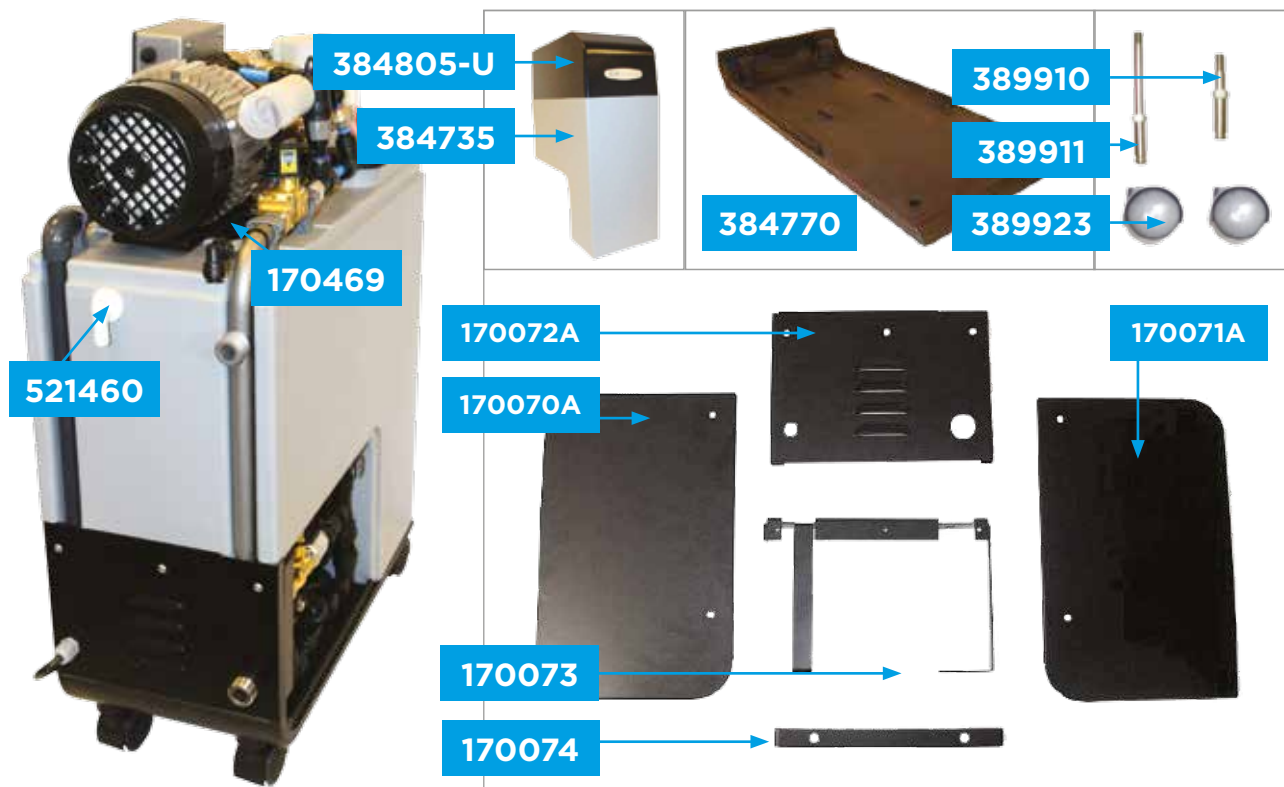

Part Number	Description	Pieces
170070A	Frame Left - Black	1
170071A	Frame Right - Black	1
170072A	Frame Back Panel - Black	1
170073	Frame Back Support - Black	1
170074	Frame Front Support - Black	1
170469	Elbow Push In 10mm	1
384735	Cabinet - 35 Litre	1
384770	Frame Base - 35 Litre	1
384805-U	Lid - 35 Litre, Black	1
389910	Short Shaft - RO	2
389911	Long Shaft - RO	2
389923	Castor - RO	4
521460	Overflow (including nut) 90°	1

RO-Compact 1 Parts: The pumps

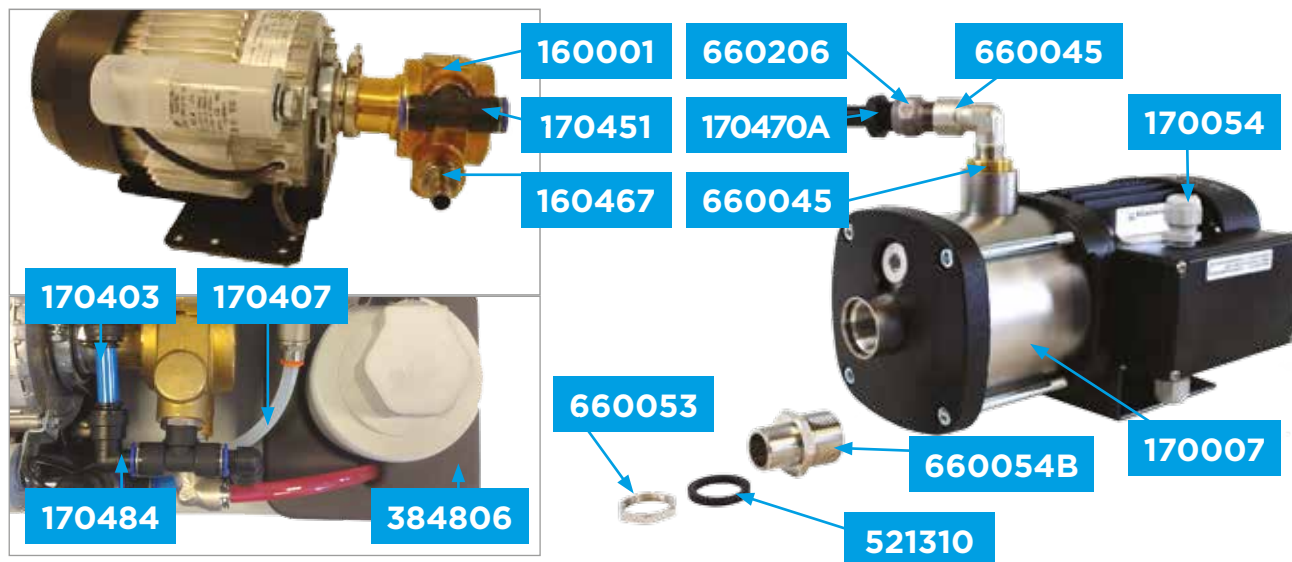

Part Number	Description	Pieces
160001	Pump 1,000 l/ph - Brass	1
160005	Motor - 560w, 230v, 50Hz	1
170007	Pump - SS, 500w, 230v, 50Hz	1
170054	Cable Gland - M20 x 1,5	2
170403	Tube - Pu 12/10 Blue	0,5
170407	Tube - Pu 10/8 Nature	0,8
170451	Tee - 1/2" x ø12 Push In	1
170467	Mw-R6 Base Male - 12-1/2"	1
170470A	Nipple ø 15mm x 1/2" bspp	1
170484	Elbow Insert	2
384806	Top Plate Compact 1	1
521310	Gasket - 3/4"	1
660026	Reduction Ms - 1" x 1/2"	1
660045	Elbow - N/M 1/2"	1
660053	Hex Jam Nut - 3/4"	1
660054B	Hex Nipple - Bspp 3/4" x Bspp 1"	1
660206	NON return valve "short"	1

RO-Compact 1 Parts: Distribution plumbing

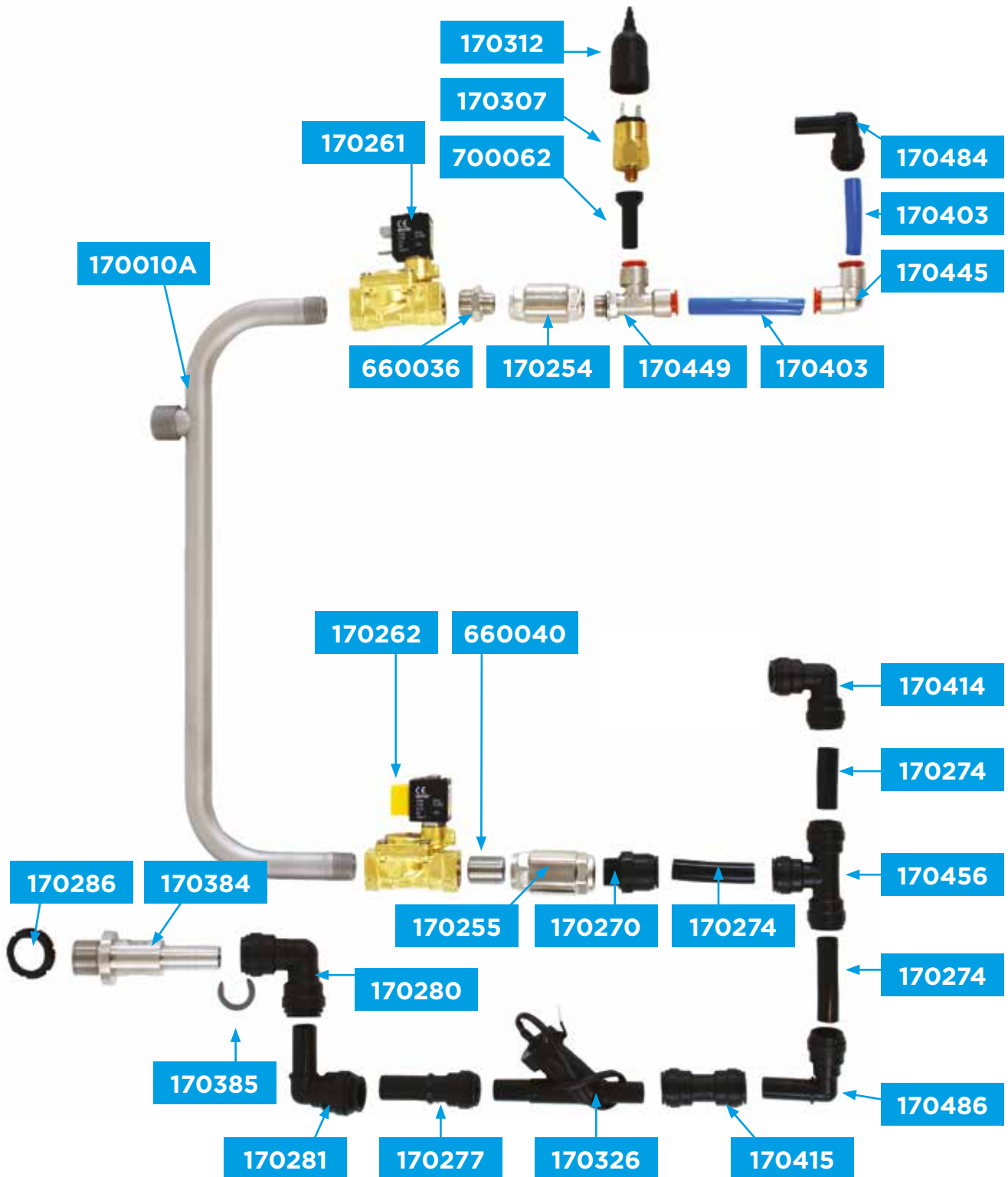

Part Number	Description	Pieces
170254	Rømer Non Return Valve - 3/8"	1
170255	Rømer Non Return Valve - 1/2"	1
170261	Sirai Solenoid Valve NC 1/2"	1
170262	Sirai Solenoid Valve NO 1/2"	1
170270	Connector for flowswitch, 15mm	1
170274	JG-tube 15mm 2 x 78mm 1 x 55mm	3
170286	Nut JG 3/4"	1
170307	Pressostat 1-10 Bar, 1/8" MS	1
170312	Cap For Pressure Switch	1
170326	Flow Switch - ø 15mm	1
170384	Permeate Outlet - 3/4" SS	1
170385	Locking Clip	1
170403	Tube Pu - 12/10 Blue (85mm)	2
170414	Elbow 15mm push in	1
170415	Connector 15mm Push In	1
170445	Elbow - 12mm	1
170449	Tee - 3/8" Push In 12mm	1
170456	JG Tee 15mm	1
170484	Stem Elbow - Push In 12mm	1
170486	Elbow Nipple 15mm	1
660036	Hex Nipple Reducer	1
660040	Nipple Pipe - SS 1/2" x 22mm	1
660053	Hex Nut Jam - 3/4"	1
700062	Nipple - PVC ø12 x 1/8"	1
170010-A	Pipesystem Stainless	1

RO-Compact 1 Parts: Membrane and components



Part Number	Description	Pieces
160521	Membrane - Compact Low 3 - 4021	1
170066	Screw - 5 x 12mm	1
170315	Level Stick - 35 Litre	1
170329	Protective Pad - 35 Litre	1
170330	Hanger for Protective Pad	1
170331	Lock Nut - M5	2
170332	Screw - 5 x 16	1
170401	Tube Pu - 12/8 Red	0,70
170447	Elbow - 1/2" x 12mm	1
170448	Elbow - Push In 12mm	1
170467	Male Base - ø12 x 1/2"	1
384903	Bottom Plate Compact 1	1

RO-Compact 1 Parts: With and without by-pass

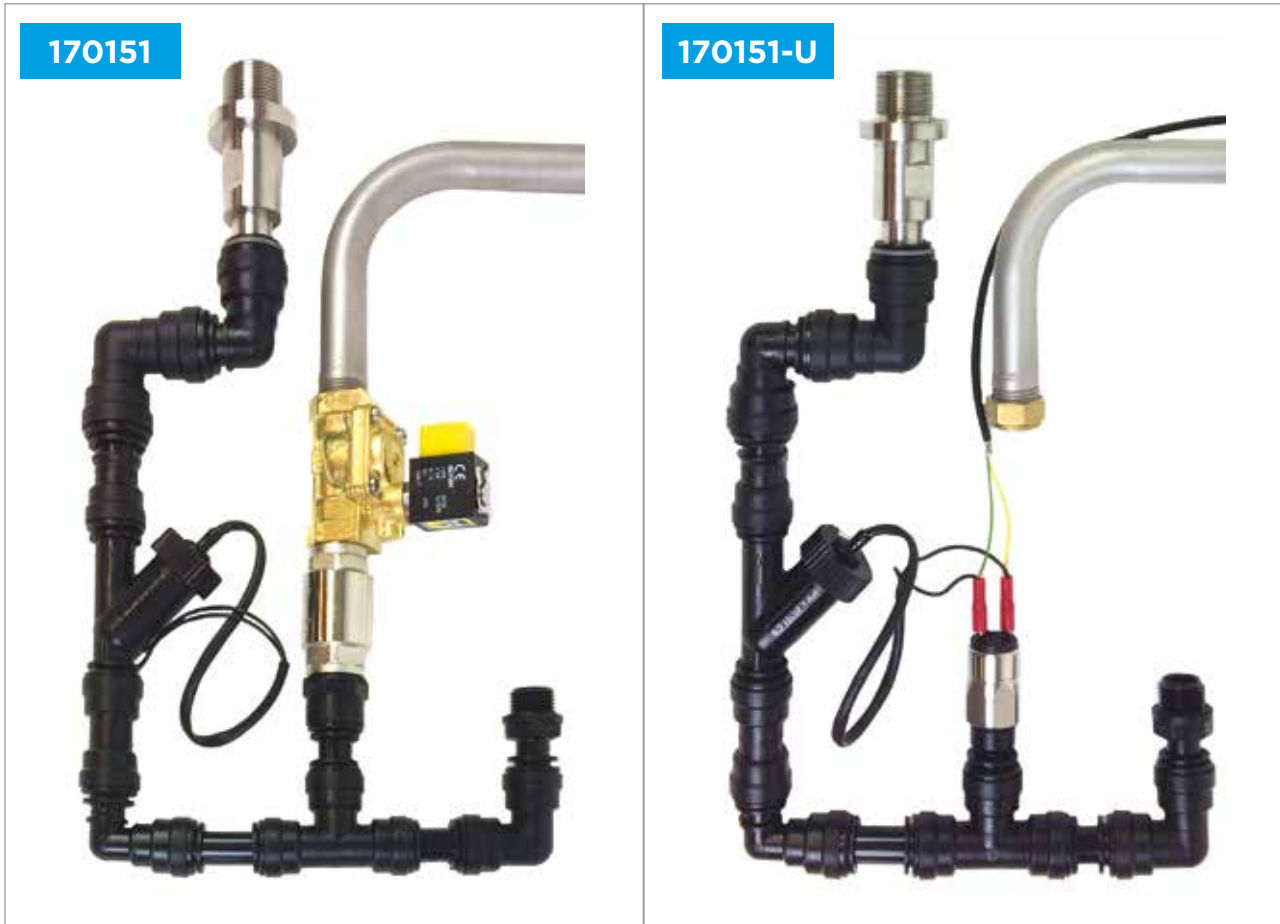

- 1** Shut off the water.
- 2** Remove top of solenoid valve, 4 screws.
- 3** Remove bottom of solenoid valve and check valve from pipe system.
- 4** Remove JG connector 18mm and tube.

- 5** install end cap on pipe system.
- 6** install pressure switch, PVC fittings 15 x 1/8".
- 7** Connect in parallel pressure-switch and flow-switch with green and yellow wires.

Part Number	Description	Pieces
170083	Red Shrouded Receptacle	2
170309	Pressure Switch - 1-10 bar, 1/8"	1
660002	Cap Nut - 1/2"	1
700061	PVC L40mm 1/8"	1

RO-Compact 1 Parts: Flow restrictors

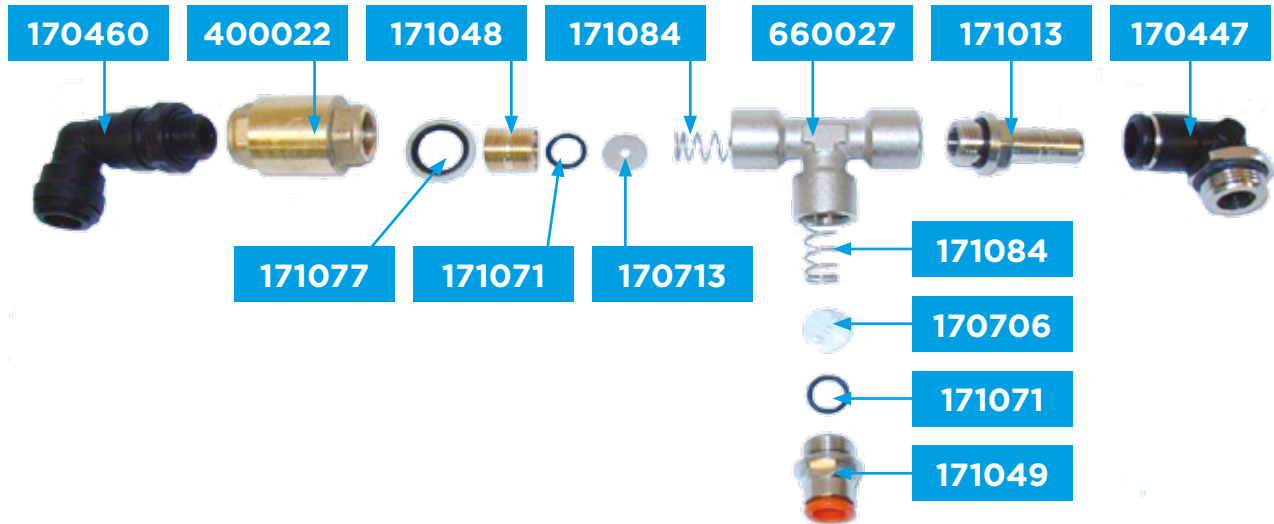

Part Number	Description	Pieces
170447	Elbow - Push In $1/2'' \times 12\text{mm}$	1
170460	Elbow - Push In $\varnothing 12 \times 3/8''$	1
170706	Nozzle No.78 (for the 0°dH setting)	1
170713	Nozzle No.115 (for the 0°dH setting)	1
171013	Base Male - $3/8'' \times 12\text{mm}$	1
171048	Circlip	1
171049	Mw - R1 $10 \times 3/8''$	1
171071	O-Ring - 10×2	2
171077	Gasket	1
171084	Spring	2
400022	Check Valve - $3/8''$ MS	1
660027	Tee - $3/8''$	1

RO-Compact 1 Parts: Complete spare parts list

Part Number	Description	Pieces
10092	Washer Overflow (BSS)	3
160001	Pump - 1,000 L/ph Brass	1
160005	Motor - 560w 230v 50Hz	1
160521	RO-Membrane - Compact Low 3 - 4021	1
170007	Grundfos Pump - Cm3 - 5	1
170010-A	Pipesystem Stainless	1
170054	Cable Gland - M20 x 1,5	3
170059	Cable Gland - PG 9	1
170066	Screw - Protective Pad	1
170069	Screw - Side frame Left/Right	8
170070A	Frame - Left, Black	1
170071A	Frame - Right, Black	1
170072A	Frame - Back Panel, Black	1
170073	Frame - Back Support, Black	1
170074	Frame - Front Support, Black	1
170083	Red Shrouded Receptacle	2
170086	Wire - 3 x 0.75mm	2
170087	Control Cable 4 Core	2
170090	Cable - 3 x 1,5mm ²	3
170093	Core Pvt 1.0 Black	1
170094	Core Pvt 1.0 - Blue	1
170095	Core Pvt 1.0 - Brown	1
170096	Core Pvt 1.0 - Yellow/Green	1
170104	Violet Shrink Tube - 0,25mm ²	6
170105	Blue Shrink Tube - 0,75mm ²	7
170106	Red Shrink Tube - 1,0mm ²	4
170107	Black Shrink Tube - 1,5mm ²	1
170108	Grey Shrink Tube - 2,5mm ²	5
170109	Washer	2

Part Number	Description	Pieces
170111	Hex Csk Head Screw - 6 x 20mm SS	3
170112	SS Socket Set Screw - 8 x 16mm RS	4
170113	SS Socket Set Screw - 8 x 30mm RS	2
170114	SS Set Screw - M5 x 10m RS	6
170115	SS Self Locking Nut - 8mm RS	4
170117	SS Plain Washer - 8mm R	6
170125	Sumitube - 9,5 12m	0,04
170126	Sumitube - 12,7mm 12m	0,01
170254	Rømer Non Return Valve - 3/8"	1
170255	Rømer Non Return Valve - 1/2"	1
170261	Sirai Solenoid Valve - NC 1/2"	1
170262	Sirai Solenoid Valve - NO 1/2"	1
170265	Sirai Connector Plug - Small	2
170270	Connector for Flowswitch, 15mm	1
170274	JG-tubing 2 x 78mm 1 x 55mm	3
170280	JG Elbow - 18mm	1
170281	JG Stem Elbow - 18mm	1
170286	Nut - 3/4"	1
170307	Pressure Switch 1 - 10 bar 1/8 "	1
170312	Hood for Pressure Switch	1
170315	Level Stick - 35 Litre	1
170326	Flow Switch - ø 15mm	1
170329	Protective Pad - 35 Litre	1
170330	Protective Rail RO	1
170331	Locknut D985	2
170332	Screw - 5 x 16	2
170384	Permeate Outlet - 3/4" SS	1
170385	Locking Clip 18mm	1
170401	Tube Pu - 12/8 Red	1
170403	Tube Pu - 12/9 Blue	0,3
170407	Tube Pu - 10/8	3
170414	Elbow push in 15 mm	1
170415	Straight Connector push in 15 mm	1
170443	Twisting Elbow - 12 x 3/8"	1

Part Number	Description	Pieces
170445	JG Elbow - 12mm	1
170447	Twisting Elbow - 12 x ½	1
170448	LG Elbow - 12mm Nickel Plated	2
170449	Tee - 3/8 " x 12mm	1
170451	Tee Screw-Push In 1/2 x ø 12 Cy	1
170456	JG Tee 15mm	1
170461	Block Screw	2
170467	Mw-R6 Base Male - 12 x ½	2
170469	Elbow - 10mm	1
170470	Nipple ø15mm x ½" bsp	1
170484	Stem Elbow - 12mm	2
170486	Elbow Nipple 15mm	1
1705	Electrical Box - RO Units	1
170706	Nozzle No. 78	1
170713	Nozzle No. 115	1
171013	Nipple - 3/8" ø 12	1
171048	Special Nipple - 3/8" MS Spec.	1
171049	Spec. Connector - 10 x 3/8"	1
171071	O-Ring - 10 x 2	2
171077	Seal 3/8"	1
171084	Spring for Nozzle	2
384735	Cabinet - 35 Litre	1
384770	Frame Base - 35 Litre	1
384805-U	Lid - Black 35 Litre	1
384806	Top Plate - Compact 1	1
384903	Bottom Plate - Compact 1	1
389910	Short Shaft - RO	2
389911	Long Shaft - RO	2
389923	Castor - RO Series	4
389940	Outer Bottom - Packaging	1
389941	Base Support A - Packaging	1
389942	Base Support B - Packaging	1
389943	Post - Packaging	4
389944	Top Support - Packaging	1

Part Number	Description	Pieces
389945	Top - Packaging	1
400021	Non Return Valve - 3/8" SS	1
521122	Wire Nut	2
521310	Seal	1
521460	Overflow (including nut)	1
521466	Metric Threaded Cap - 3/4"	2
651400	Prefilter - 3/4"	1
660026	Reduction MS - 1" x 1/2"	1
660027	Tee - 3/8"	1
660036	Hex Nipple Reducer - 3/8" x 1	1
660040	Nipple Pipe Brass - 1/2" x 22mm	1
660045	Elbow M/N - 1/2"	1
660053	Hex Jam Nut - 3/4"	1
660054B	Nipple for Checkvalve	1
660206	NON return valve "short"	1
700001	PVC Elbow - 20mm Giv 90°	1
700029	PVC Socket - Mifv 20 x 1/2"	1
700062	Nipple PVC 12 x 1/8"	1
700901	PVC Hanger - 20mm W Safety Clip	2
700902	PVC Hanger - 25mm W Safety Clip	1
700951	PVC Pipe - 20mm	0,4

RO-Compact 2 Parts: The cabinet and frame



Part Number	Description	Pieces
190061	Bottom frame with rolls	1
384736	Cabinet 66 litre	1
384804	C2 lid for RO-Compact 2 & 3 Black	1

RO-Compact 2 Parts: The pumps

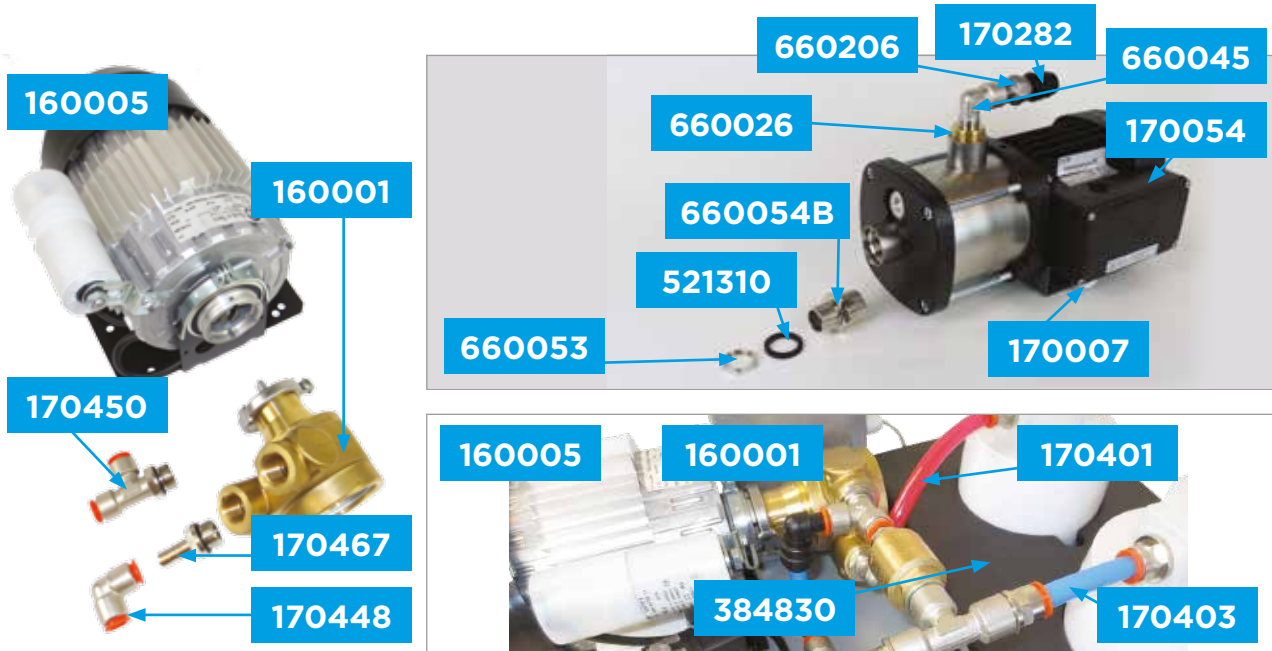

Part Number	Description	Pieces
160001	Pump - 1,000 l/ph, Brass	1
160005	Motor - 560w, 230v, 50Hz	1
170007	Pump SS - 500w, 230v, 50Hz	1
170054	Cable Gland - M20 x 1,5	2
170282	Connector 18mm x ½"	1
170403	Tube Pu - 12/10 Blue	0,5
170407	Tube Pu - 10/8 Nature	0,8
170451	Tee - ½" x ø 12 Push In	1
170467	Mw R6 - Base Male, 12 - ½"	1
170484	Elbow Insert	2
384830	Top Plate - Compact 2	1
521310	Gasket - ¾"	1
660026	Reduction MS - 1" x ½"	1
660045	Elbow - N/M ½"	1
660053	Hex Jam Nut - ¾"	1
660054B	Hex Nipple - Bspp ¾" x Bspp 1"	1
660206	NON return valve "short" ½"	1

RO-Compact 2 Parts: Membrane and components

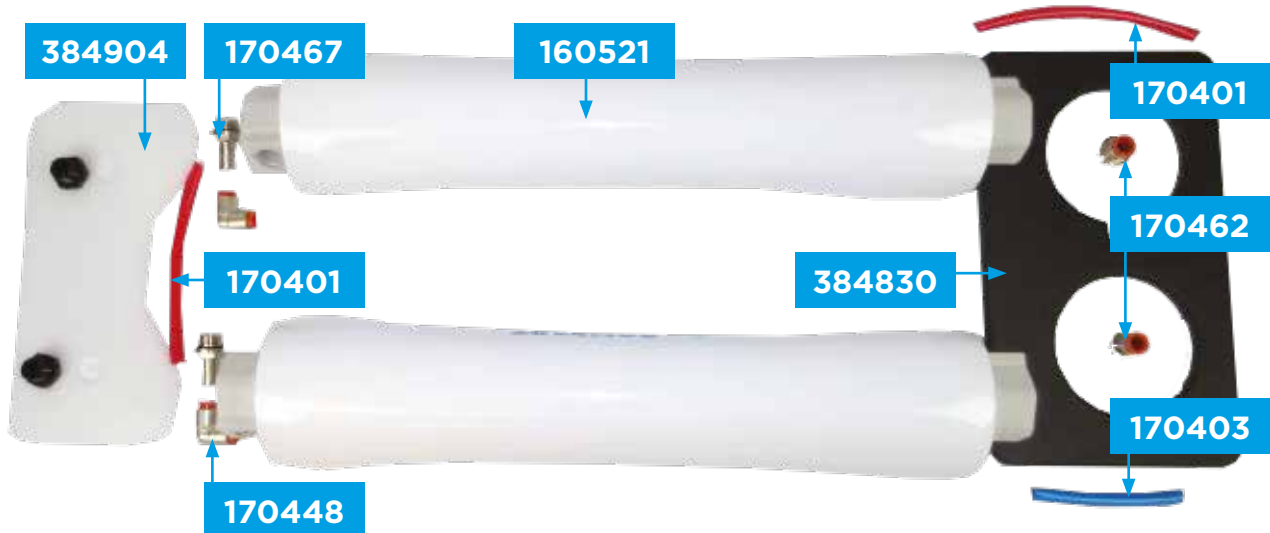

Plastic nut is included with the membrane.
6 x 3mm holes need to be drilled.



170316



Part Number	Description	Pieces
160521	RO-Membrane - Compact Low3 - 4021	2
170316	Level stick - 66 litre	1
170401	Tube pu - 12/8 red (200mm, 180mm)	2
170403	Tube pu - 12/10 blue (120mm)	1
170448	Elbow - \varnothing 12 push in	2
170462	Connector - \varnothing 12 x 1/2" push in	2
170467	Base male \varnothing 12 x 1/2"	2
384830	Top plate - compact 2	1
384904	Bottom plate - compact 2 & 3	1

RO-Compact 2 Parts: Plumbing feed water

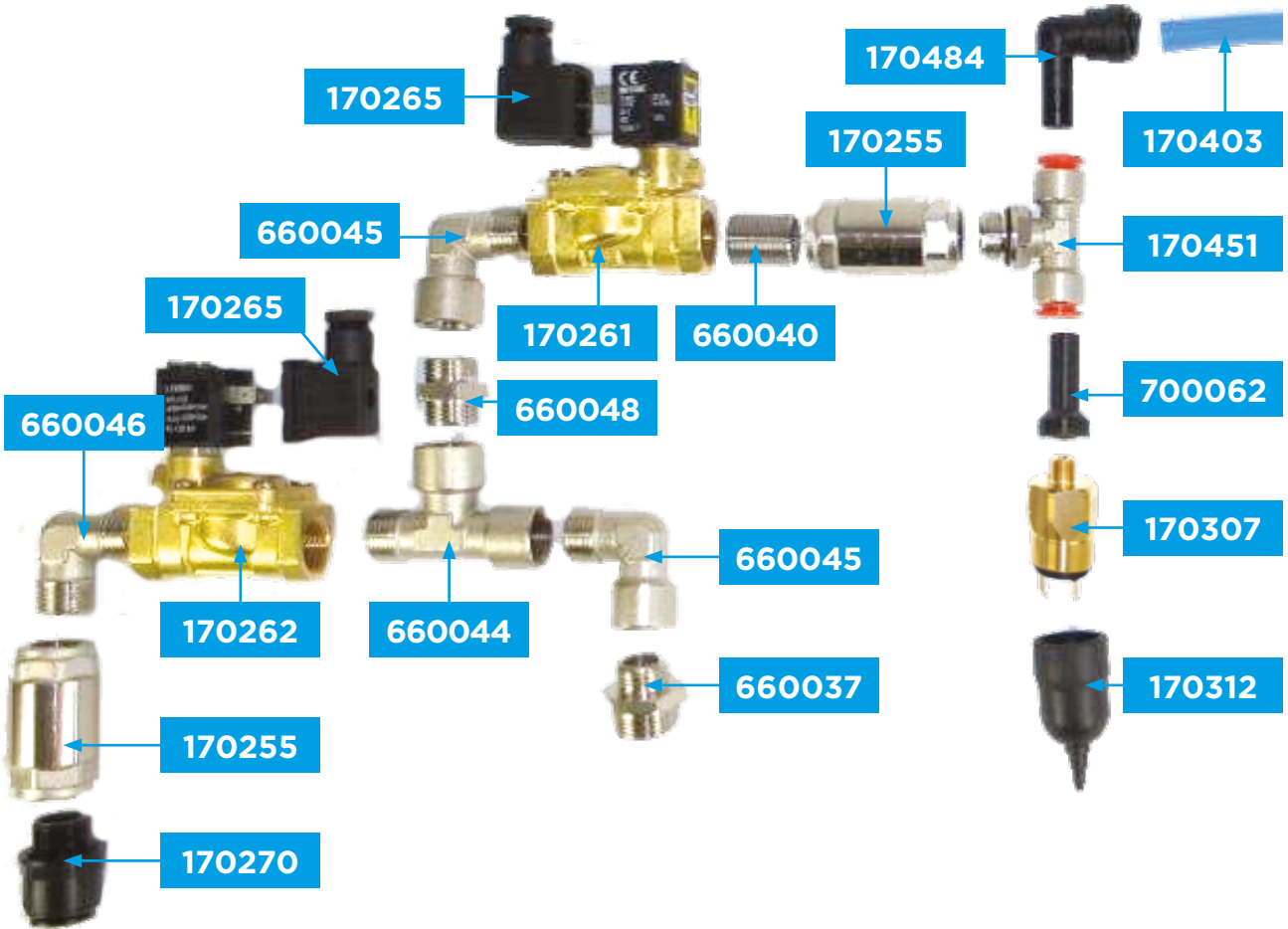



Part Number	Description	Pieces
170255	Non Return Valve - 1/2"	2
170261	Solenoid valve NC - 1/2"	1
170262	Solenoid valve NO - 1/2"	1
170265	Sirai Connector Plug	2
170270	Connector for Flow Switch - 15mm	1
170311	Pressure Switch - 1/8" (preset at 1 bar)	1
170312	Hood For Pressure Switch	1
170403	Tube Pu - 12/9 Blue (length 45mm)	0,045
170451	Push In Tee - ø 12 x 1/2"	1
170484	Insert Elbow - 12mm Push In	2
660037	Nipple - 1/2"- 3/4" N/N	1
660040	Nipple Pipe - 1/2" x 25mm	1
660044	Tee - 1/2"	1
660045	Elbow - M/N 1/2"	2
660046	Elbow - N/N 1/2"	1
660048	Nipple - 1/2"	1
700062	Nipple PVC - ø 12 x 1/8"	1

RO-Compact 2 Parts: Distribution plumbing

660001 - Reduction $\frac{3}{4}$ " - $\frac{1}{2}$ " in between elbow and connector.

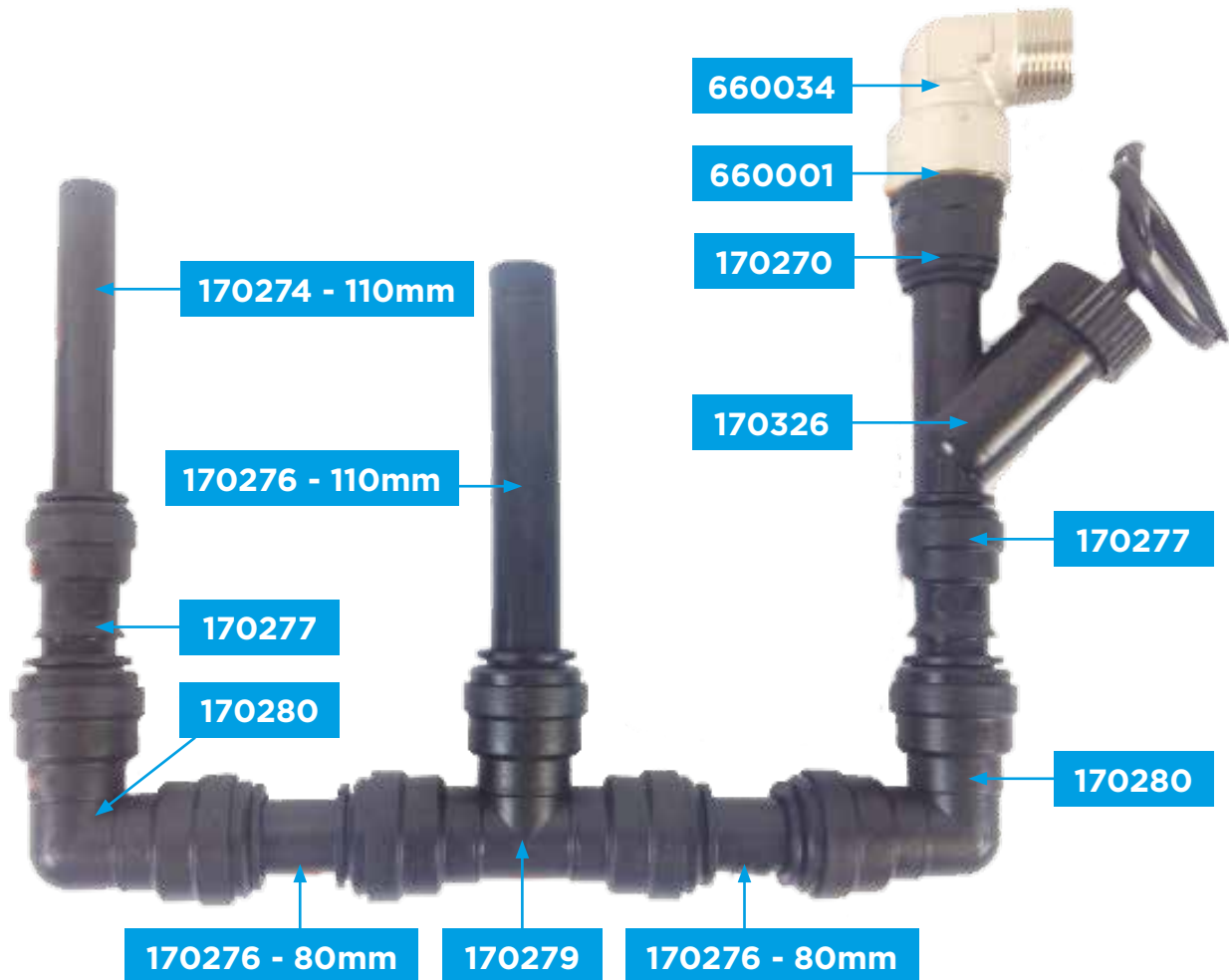

Part Number	Description	Pieces
170270	Connector for Flow switch - 15mm	1
170274	JG Tube - \varnothing 15mm	0,11
170276	JG Tube - \varnothing 18mm	0,27
170277	JG Reduction - \varnothing 18 x 15mm	2
170279	JG Tee - 18mm	1
170280	JG Elbow - \varnothing 18 mm	2
170326	Flow Switch - \varnothing 15mm	1
660001	Reduction	1
660034	Elbow - $\frac{3}{4}$ " Bsp	1

RO-Compact 2 Parts: Flow restrictors

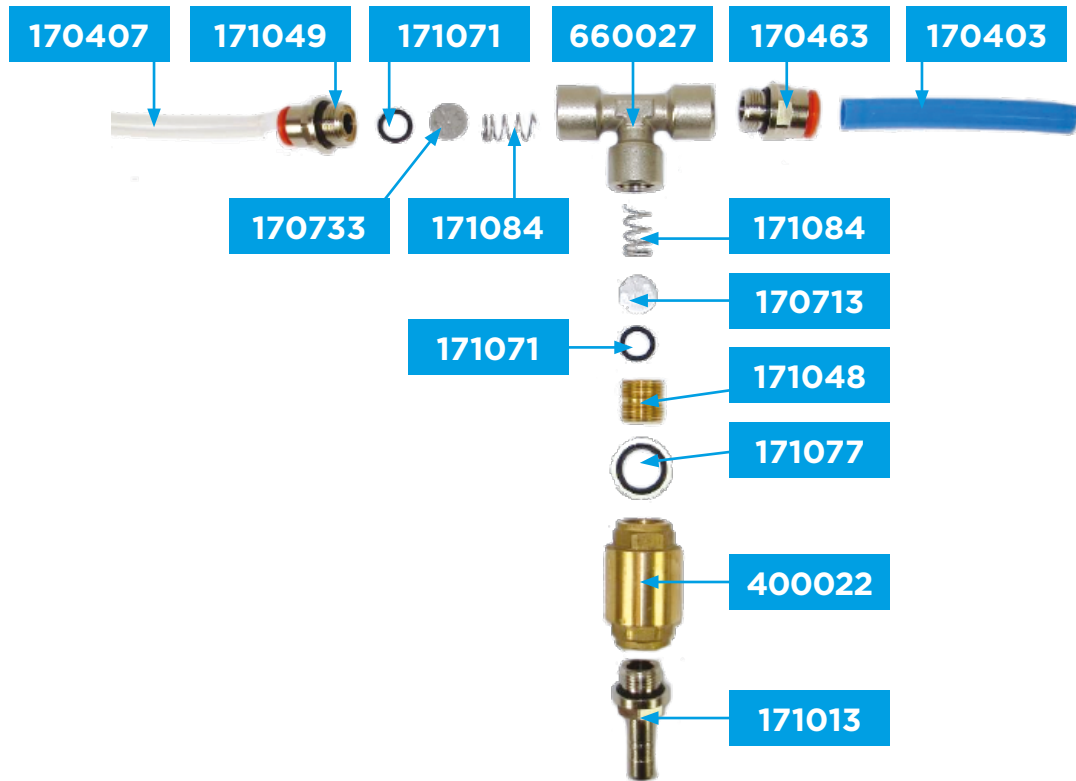

Part Number	Description	Pieces
170403	Tube Pu - 12/10 Blue	1
170407	Tube Pu - 10/8 Nature	2
170463	Connector - 12 - 3/8	1
170733	Nozzle No. 43 (drain) (for the 0°dH setting)	1
170713	Nozzle No. 115 (circulation) (for the 0°dH setting)	1
171013	Base Male - 3/8" x 12mm	1
171048	Special Nipple	1
171049	Special Connector - 10 x 3/8"	1
171071	O-Ring - 10 x 2	2
171077	Gasket	1
171084	Spring	2
400022	Check Valve - 3/8" Brass	1
660027	Tee - 3/8"	1

RO-Compact 2 Parts: Complete spare parts list

Part Number	Description	Pieces
10092	Washer overflow (bss)	4
1328	O-ring	1
160001	Pump - 1000 l/ph, brass	1
160005	Motor - 560w 230v 50Hz	1
160521	RO-Membrane - compact low3 - 4021	2
170007	Grundfos pump 3 - 5cm	1
170054	Cable gland - 20m x 1,5	1
170058	Cable gland - pg 11	2
170059	Cable gland - pg 9	3
170083	Red shrouded receptacle	2
170086	Wire - 3 x 0,75mm	2
170087	Control cable - 4 core	2
170090	Cable - 3 x 1,5 mm ²	3
170094	Core pvt - 1.0 Blue	0,3
170095	Core pvt - 1.0 Brown	0,1
170097	Cable - 5 x 1 mm ²	1
170104	Violet shrink tube - 0,25mm ²	6
170105	Blue shrink tube - 0,75mm ²	16
170106	Red shrink tube - 1,0mm ²	10
170107	Black shrink tube - 1,5mm ²	3
170108	Grey shrink tube - 2,5mm ²	4
170109	Washer	6
170111	Hex csk head screw 6 x 20mm SS	6
170114	Set screw m5 x 10m RS	6
170115	SS self locking nut - 8mm RS	2
170117	SS plain washer 8mm RS	4
170118	Set screw - 8 x 45mm SS	4
170122	Set screw - 8 x 20mm SS	2
170255	Rømer non return valve - ½"	2
170261	Sirai solenoid valve NC ½"	1

Part Number	Description	Pieces
170262	Sirai solenoid valve NO ½"	1
170265	Sirai connector plug - small	2
170270	Connector for flow switch 15mm	2
170274	JG tube - 15mm (1m)	0,11
170276	JG tube - 18mm (1m)	0,29
170277	JG reducer - 18 x 15	2
170279	JG tee - 18mm	1
170280	JG elbow - 18mm	2
170282	JG connector - 18mm x ½"	1
170285	Bulkhead connector - 1"	1
170311	Pressure switch - 1 - 10 bar 1/8 "	1
170312	Hood for pressure switch	1
170316	Level switch - 66 litre	1
170326	Flow switch - ø 15mm	1
170401	Tube pu - 12/8 red	0,4
170403	Tube pu - 12/9 blue	0,2
170407	Tube pu - 10/8	2
170448	LG Elbow - 12mm Nickel plated	3
170450	Flexible tee - ½" x ø12	1
170451	Tee Screw-Push In 1/2" X Ø12 cy	1
170461	Block screw	1
170462	Connector - ø 12 x ½ push in	2
170463	Connector - 12 x 3/8 "	1
170467	Mw - r6 base male - 12 - ½	3
170484	Stem elbow - 12mm	2
1705	Electrical box	1
170501	4a fuse with sand	1
170713	Nozzle no. 115	1
170733	Nozzle no. 43	1
171013	Nipple - 3/8" ø 12	1
171048	Special nipple - 3/8"ms spec.	1
171049	Spec. Connector 10 x 3/8"	1
171071	O-ring - 10 x 2	2
171077	Seal - 3/8 "	1
171077	Seal - 3/8 "	1

Part Number	Description	Pieces
171084	Spring for nozzle	2
190050	Mounting box RO	1
190051	Terminal - ground	3
190053	Terminal - blue	4
190054	Terminal - grey	4
190056	Deep top hat punched	0,13
190061	Bottom frame with rolls	1
380070	Outer box without bottom	1
384736	Cabinet RO 66 litre	1
384804-C2	Lid - RO-Compact 2 & 3, black	1
384830	Top plate - RO-Compact 2	1
384904	Bottom plate - RO-Compact 2 & 3	1
400021	Non return valve - 3/8" SS	1
521122	Wire nut	2
521310	Seal	1
521466	Metric threaded cap - 3/4"	2
651400	Prefilter - 3/4"	1
660001	Red Short - 3/4" x 1/2"	1
660026	Reduction - ms 1" x 1/2"	1
660027	Tee - 3/8"	1
660034	Elbow - n/m 3/4"	1
660037	Nipple - 3/4" x 1/2"	1
660040	Nipple pipe brass - 1/2" x 22mm	1
660044	Tee m/m/n - 1/2"	1
660045	Elbow m/n - 1/2"	2
660046	Elbow nn - 1/2 "	1
660048	Nipple - 1/2" x 25mm	1
660053	Hex jam nut - 3/4"	1
660054B	Nipple for check valve	1
660206	NON return valve "short"	1
700062	Nipple PVC - 12 x 1/8"	1
700902	PVC hanger 25mm with safety clip	1
700903	PVC hanger 32mm	3

RO-Compact 3 Parts List: The cabinet and frame



Part Number	Description	Pieces
190061	Base Frame	1
384736	Cabinet RO - 66 litre	1
384804-C2	Lid For RO-Compact 2 & 3 - Black	1

RO-Compact 3 Parts: The pumps

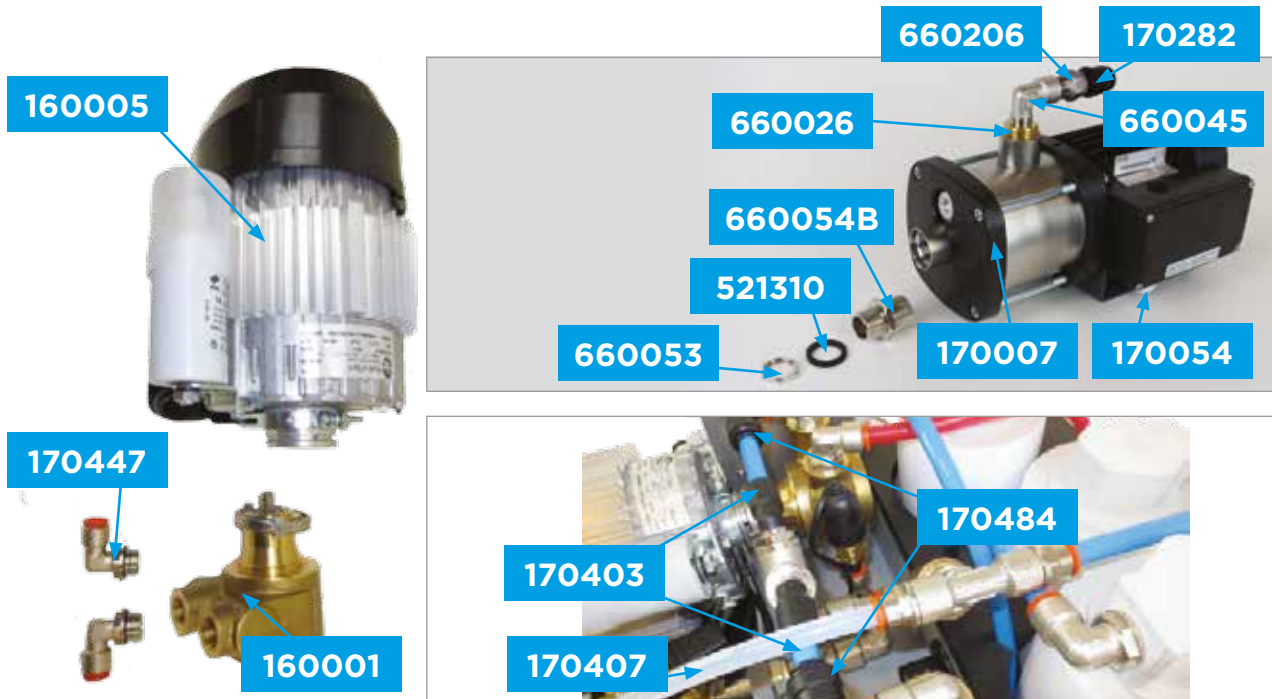

Part Number	Description	Pieces
160001	Pump - 1,000 l/ph Brass	2
160005	Motor - 560w, 230v, 50Hz	2
170007	Pump - SS, 500w, 230v, 50Hz	1
170054	Cable Gland - 20m x 1,5	1
170282	Connector - 18mm x ½"	1
170403	Tube Pu - 12/10 Blue (2 x 60mm)	0,12
170407	Tube Pu - 10/8 Nature	2,5m
170447	Twisting Elbow - 12 x ½	4
170469	Elbow Push In - 10mm (drain)	1
170484	Stem Elbow - 12mm	2
521310	Gasket - ¾"	1
660026	Reduction - Ms 1" x ½"	1
660045	Elbow - N/M ½"	1
660053	Hex Jam Nut - ¾"	1
660054B	Hex Nipple - ¾" x 1"	1
660206	NON return valve "short"	1

RO-Compact 3 Parts: Membrane and components



Part Number	Description	Pieces
160521	RO-Membrane - Compact Low 3-4021	3
170316	Level Switch - 66 litre	1
170401	Tube Pu - 12/8 Red (2 x 800mm)	2
170403	Tube Pu - 12/10 Blue (2 x 850mm)	2
170447	Flexible Elbow - $\varnothing 12 \times \frac{1}{2}$ "	3
170448	Elbow - $\varnothing 12$ Push In	2
170455	Tee - 12mm Push In	1
170467	Base Male - $\varnothing 12 \times \frac{1}{2}$ "	3
384831	Top Plate - RO-Compact 3	1
384904	Bottom Plate - RO-Compact 2 & 3	1

RO-Compact 3 Parts: Plumbing feed water

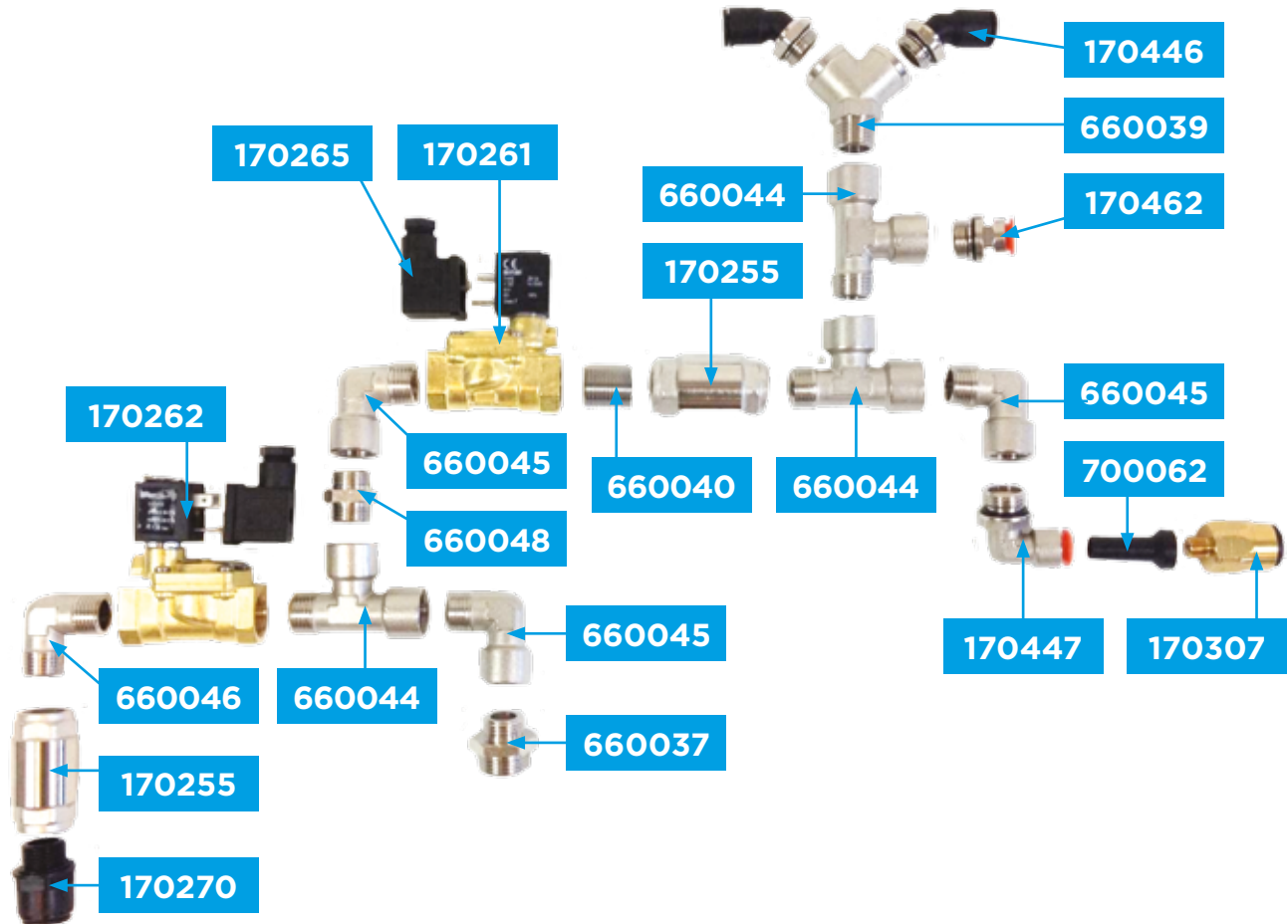



Part Number	Description	Pieces
170255	Non Return Valve - ½"	2
170261	Solenoid valve - NC ½"	1
170262	Solenoid valve - NO ½"	1
170265	Sirai Connector Plug	2
170270	Connector for Flow switch - 15mm	1
170307	Pressure Switch 1/8" (preset at 1 Bar)	1
170312	Hood for Pressure Switch	1
170446	LG 45° Male Elbow - 12 x ½"	2
170447	Twisting Elbow - ø12x½"	1
170462	Connector - ø12 x ½" Push In	1
660037	Nipple - ½"- ¾" N/N	1
660039	Y-Piece - ½"	1
660040	Nipple Pipe ½" x 25mm	1
660044	Tee - ½"	3
660045	Elbow - M/N ½"	3
660046	Elbow - N/N ½"	1
660048	Nipple - ½"	1
700062	Nipple PVC - ø12 x 1/8"	1
660056	Elbow - ½" (only used with no-bypass)	1

RO-Compact 3 Parts: Distribution plumbing

660001 - Reduction $\frac{3}{4}$ " - $\frac{1}{2}$ " in between elbow and connector.



Part Number	Description	Pieces
170270	Connector for Flow switch - 15mm	1
170274	JG Tube - \varnothing 15mm	0,11
170276	JG Tube - \varnothing 18mm	0,27
170277	JG Reduction - \varnothing 18 x 15	2
170279	JG Tee - 18mm	1
170280	JG Elbow - \varnothing 18	2
170326	Flow switch - \varnothing 15mm	1
660001	Reduction	1
660034	Elbow - $\frac{3}{4}$ " Bsp	1

RO-Compact 3 Parts: Flow restrictors

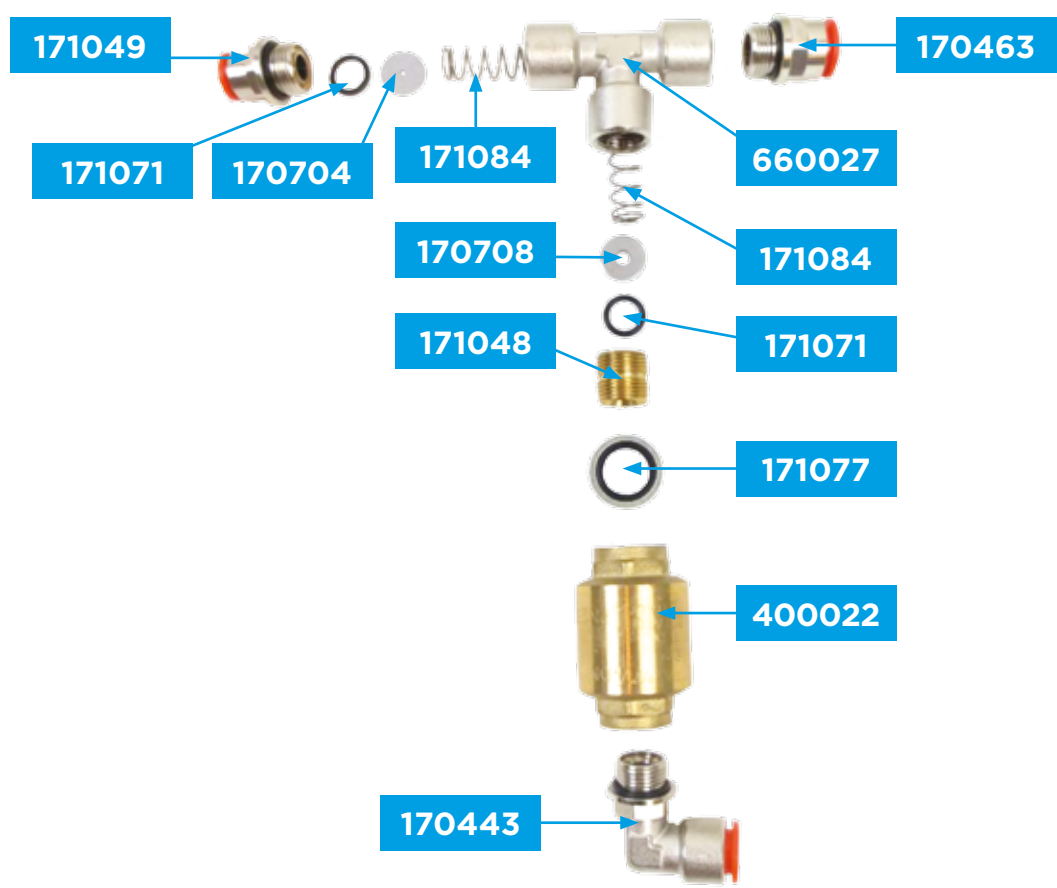

Part Number	Description	Pieces
170443	Twisting Elbow - ø12 x 3/8"	1
170463	Connector - 12 - 3/8	1
170704	Nozzle No. 59 (drain) (for 0°dH setting)	1
170708	Nozzle No.177 (circulation) (for 0°dH setting)	1
171048	Special Nipple	1
171049	Special Connector - 10 x 3/8"	1
171071	O-Ring - 10 x 2	2
171077	Gasket	1
171084	Spring	2
400022	Check Valve - 3/8" Brass	1
660027	Tee - 3/8"	1

RO-Compact 3 Parts: Complete spare parts list

Part Number	Description	Pieces
10092	Washer Overflow (Bss)	4
1328	O-Ring	1
160001	Pump - 1000 l/ph, Brass	2
160005	Motor - 560w, 230v, 50Hz	2
160521	RO-Membrane - Compact Low 3 - 4021	3
170007	Grundfos Pump - Cm3 - 5	1
170054	Cable Gland - 20m x 1,5	1
170058	Cable Gland Pg 11	2
170059	Cable Gland Pg 9	4
170083	Red Shrouded Receptacle	2
170086	Wire - 3 x 0,75mm	2
170087	Control Cable - 4 Core	2
170090	Cable 3 x 1,5mm ²	3
170094	Core Pvt 1.0 - Blue	0,3
170095	Core Pvt 1.0 - Brown	0,15
170097	Cable - 5 x 1mm ²	1
170104	Violet Shrink Tube - 0,25mm ²	6
170105	Blue Shrink Tube - 0,75mm ²	18
170106	Red Shrink Tube - 1,0mm ²	12
170107	Black Shrink Tube - 1,5mm ²	3
170108	Grey Shrink Tube - 2,5mm ²	6
170109	Washer	6
170111	Hex Csk Head Screw - 6 x 20mm SS	6
170114	Set Screw - M 5 x 10 M RS	10
170115	SS Self Locking Nut - 8mm RS	2
170117	SS Plain Washer - 8mm RS	4
170118	Set Screw - 8 x 45mm SS	4
170122	Set Screw 8 x 20mm SS	2
170255	Rømer Non Return Valve 1½"	2
170261	Sirai Solenoid Valve - NC ½"	1

Part Number	Description	Pieces
170262	Sirai Solenoid Valve - NO ½"	1
170265	Sirai Connector Plug - Small	2
170270	Connector for Flow switch - 15mm	2
170274	JG Tube - 15mm (1m)	0,11
170276	JG Tube - 18mm (1m)	0,28
170277	JG Reducer - 18 x 15	2
170279	JG Tee - 18mm	1
170280	JG Elbow - 18 Mm.	2
170282	JG Connector - 18mm x ½"	1
170285	Bulkhead Connector - 1"	1
170311	Pressure Switch - 1-10 bar 1/8"	1
170312	Hood for Pressure Switch	1
170316	Level Switch - 66 litre	1
170326	Flow Switch - ø15mm	1
170401	Tube Pu 12/8 - Red	2
170403	Tube Pu 12/9 - Blue	2
170407	Tube Pu - 10/8	2
170443	Twisting Elbow - ø12 x 3/8"	1
170446	Lg 45° Male Elbow - 12 x ½"	2
170447	Twisting Elbow - 12 x ½	8
170448	LG Elbow - 12mm Nickel Plated	2
170455	JG Tee - 12mm	1
170461	Block Screw	1
170462	Connector - ø12 x ½ Push In	1
170463	Connector - 12 x 3/8"	1
170467	Mw-R6 - Base Male, 12 - ½	3
170469	Elbow - 10mm	1
170484	Stem Elbow - 12mm	2
1705	Electrical Box - RO Units	1
170501	4A - Fuse with Sand	1
170704	Nozzle No. 59	1
170708	Nozzle No. 177	1
171048	Special Nipple - 3/8" Ms Spec.	1
171049	Spec. Connector 10 x 3/8"	1
171071	O-Ring - 10 x 2	2

Part Number	Description	Pieces
171077	Seal 3/8"	1
171084	Spring for Nozzle	2
190050	Mounting Box	1
190051	Terminal - Ground	4
190053	Terminal - Blue	5
190054	Terminal - Grey	5
190056	Deep Top Hat Punched	0,13
190061	Bottom frame with Rolls	1
380070	Outer box without Bottom	1
384736	Cabinet - RO 66 litre	1
384804-C2	Lid - RO-Compact 2 & 3, Black	1
384831	Top Plate - RO-Compact 3	1
384904	Bottom Plate - RO-Compact 2 & 3	1
400021	Non Return Valve 3/8" SS	1
521122	Wire Nut	2
521310	Seal	1
521466	Metric Threaded Cap - 3/4"	2
651400	Pre-filter - 3/4"	1
660001	Red Short - 3/4" x 1/2"	1
660026	Reduction MS - 1" x 1/2"	1
660027	Tee - 3/8"	1
660034	Elbow - N/M 3/4"	1
660037	Nipple - 3/4" x 1/2"	1
660039	Y-Piece - 1/2" M/N/M	1
660040	Nipple Pipe Brass - 1/2" x 22mm	1
660044	Tee - M/M/N 1/2"	3
660045	Elbow - M/N 1/2"	4
660046	Elbow - Nn 1/2"	1
660048	Nipple - 1/2" x 25mm	1
660053	Hex Jam Nut - 3/4"	1
660054B	Nipple for Check valve	1
660206	NON return valve "short"	1
700062	Nipple PVC - 12 x 1/8"	1
700902	PVC Hanger - 25mm with Safety Clip	1
700903	PVC Hanger - 32mm	3

RO-Compact with bypass



Part Number	Description	Pieces
170153	RO-Compact 3	
170152	RO-Compact 2	

RO-Compact without bypass



Part Number	Description
170153-U	RO-Compact 3 without bypass
170152-U	RO-Compact 2 without bypass

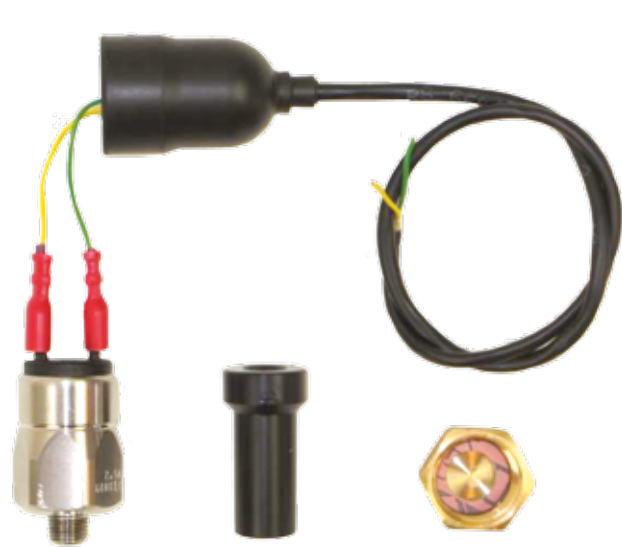

Pressure switch preset at 1,6 bar

By-pass conversion kit - 170018:

1. Shut off the water.
2. Remove cable/wire from elbow.
3. Remove top of solenoid valve, 4 screws.
4. Remove bottom of solenoid valve, together with check valve from pipe system.
5. Remove JG connector 18mm and tube.
6. Install end cap on pipe system.
7. Install pressure switch, PVC fittings 15 x 1/8" and reducer 18 x 15.
8. Connect parallel pressure-switch and flow-switch with green and yellow wires.

Part Number	Description	Pieces
170083	Red Shrouded Receptacle	2
170277	JG Reducer 18 x 15	1
170309	Pressure Switch 1 - 10 Bar - 1/8"	1
660002	Cap Nut - 1/2"	1
700061	PVC L40mm - 1/8"	1
170312	Hood for Pressure Switch	1
170087	Wire (50cm)	0,50

Electrical Parts

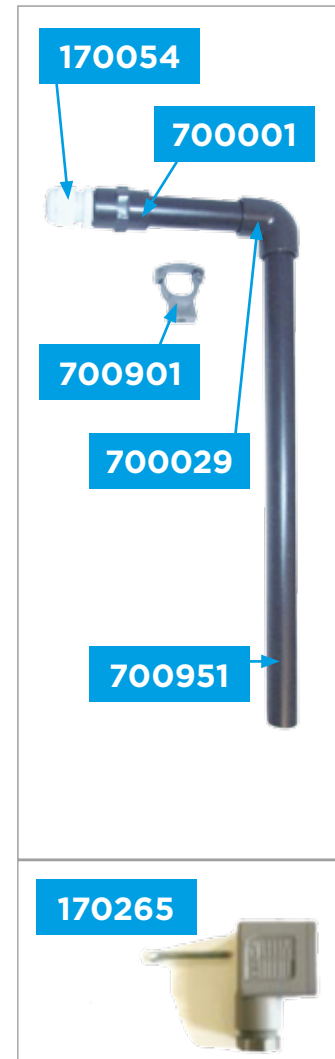

Part Number	Description	Pieces
1705	Electrical Box for RO-Units	1
170054	Cable Gland PG 13,5	1
170265	Sirai Connector Plug	1
700001	PVC 90° Elbow Giv 1/2"	1
700029	PVC Socket Mifv 20 x 1/2"	1
700901	PVC Hanger 20mm	1
700951	PVC Pipe Ø 20mm Pn16 83mm & 310mm	0,4

Electrical Boxes

RO-Compact 1:

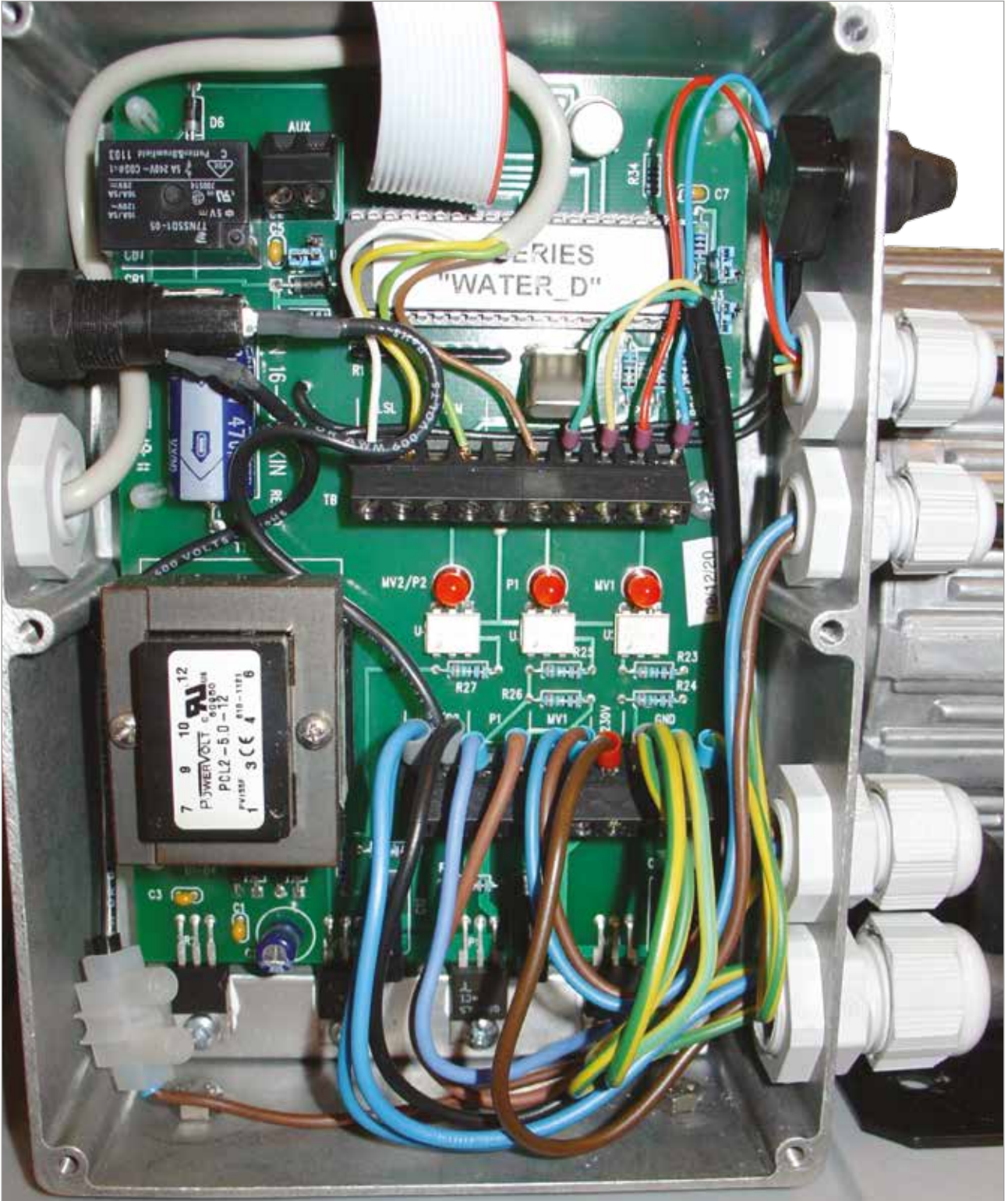

RO-Compact 2 and 3:

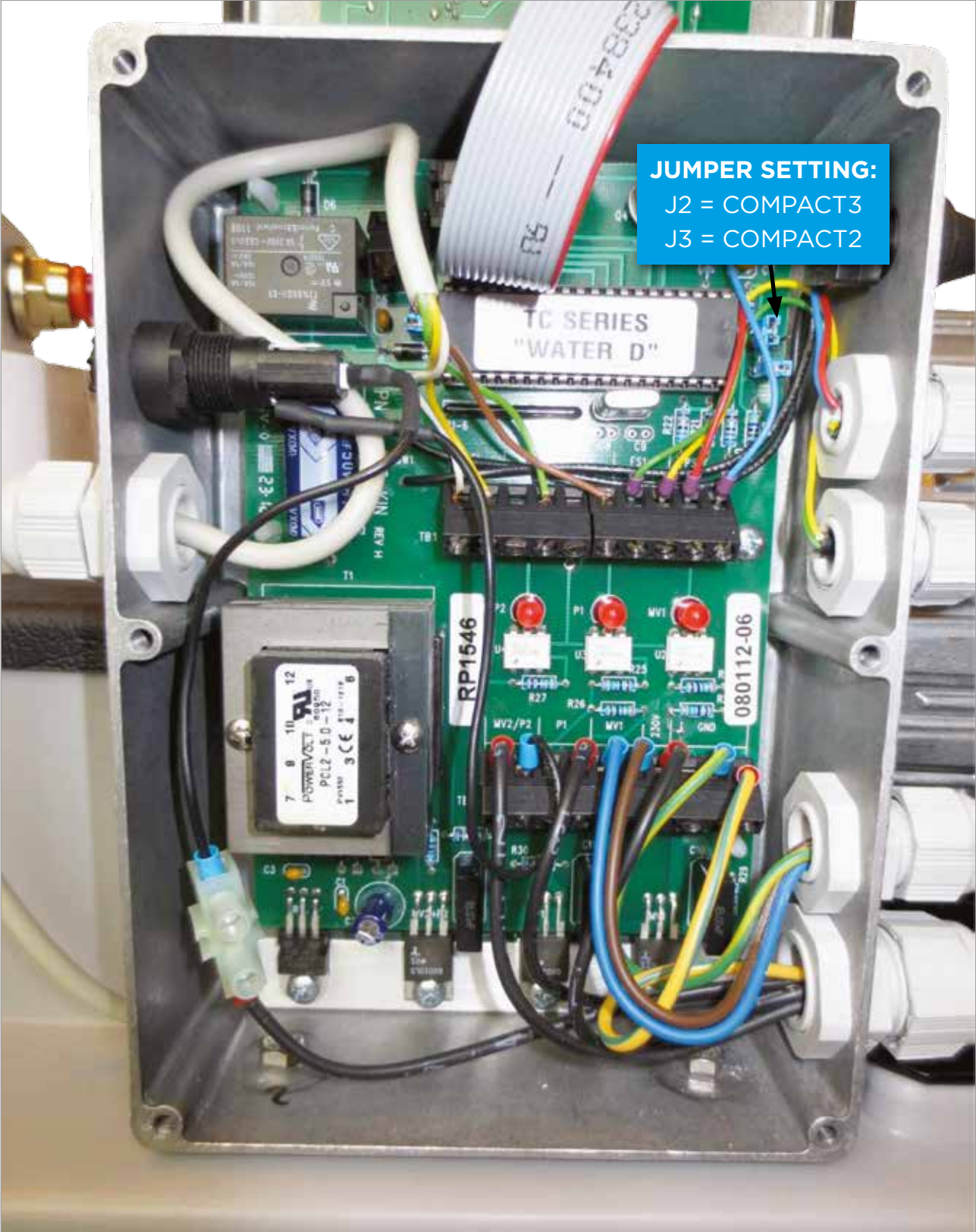

Terminal Block Wiring

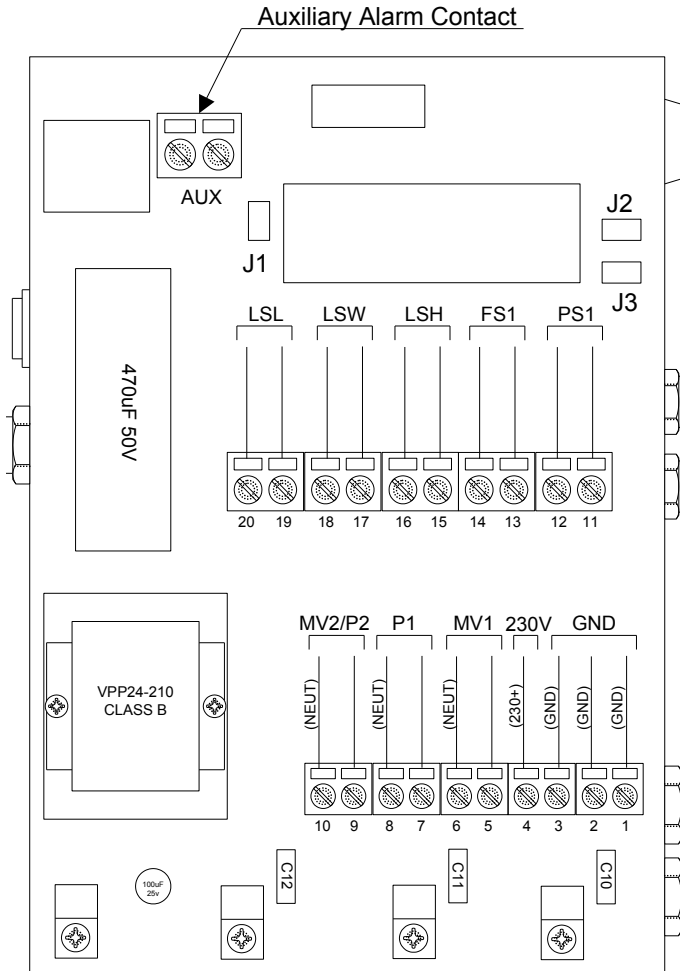

- 1 Ground
- 2 Ground
- 3 Ground
- 4 Main power, line voltage (brown)
- 5 Feed solenoid valve, line voltage (brown)
- 6 Feed solenoid valve, neutral (blue)
- 7 Feed pump, line voltage (brown)
- 8 Feed pump, neutral (blue)
- 9 Process pump, line voltage (brown)
- 10 Process pump, neutral (blue)
- 11 Pressure switch, signal voltage
- 12 Pressure switch, signal voltage
- 13 Flow switch, signal voltage
- 14 Flow switch, signal voltage
- 15 High level switch, signal voltage (brown)
- 16 High level switch, signal voltage
- 17 Mid level switch, signal voltage (green)
- 18 Mid level switch, signal voltage
- 19 Low level switch, signal voltage (yellow)
- 20 Low level switch, signal voltage (brown)

Jumpers:

J1 on

Use LSH for P1 turn on

J1 off

Use LSM for P1 turn on

System	J1	J2	J3
RO-Compact 1	0	0	0
RO-Compact 2	0	0	1
RO-Compact 3	0	1	0

System	Volume (Litres)	Alarm Settings			
		Minimum l/ph	Maximum l/ph	Min Time (mins)	Max Time (mins)
RO-Compact 1	9,1	100	350	5,28	1,34
RO-Compact 2	18,2	133	470	8,13	2,19
RO-Compact 3	17,4	280	820	3,44	1,16

RO-Compact 2:

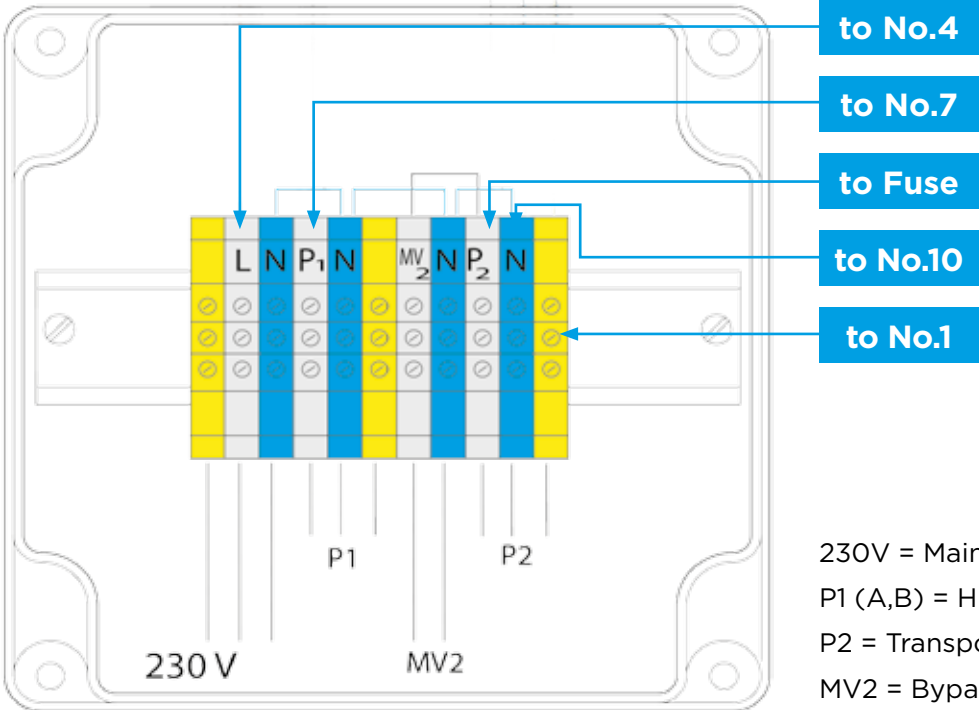

230V = Main cable
 P1 (A,B) = High pressure pump
 P2 = Transport pump
 MV2 = Bypass solenoid

RO-Compact 3:

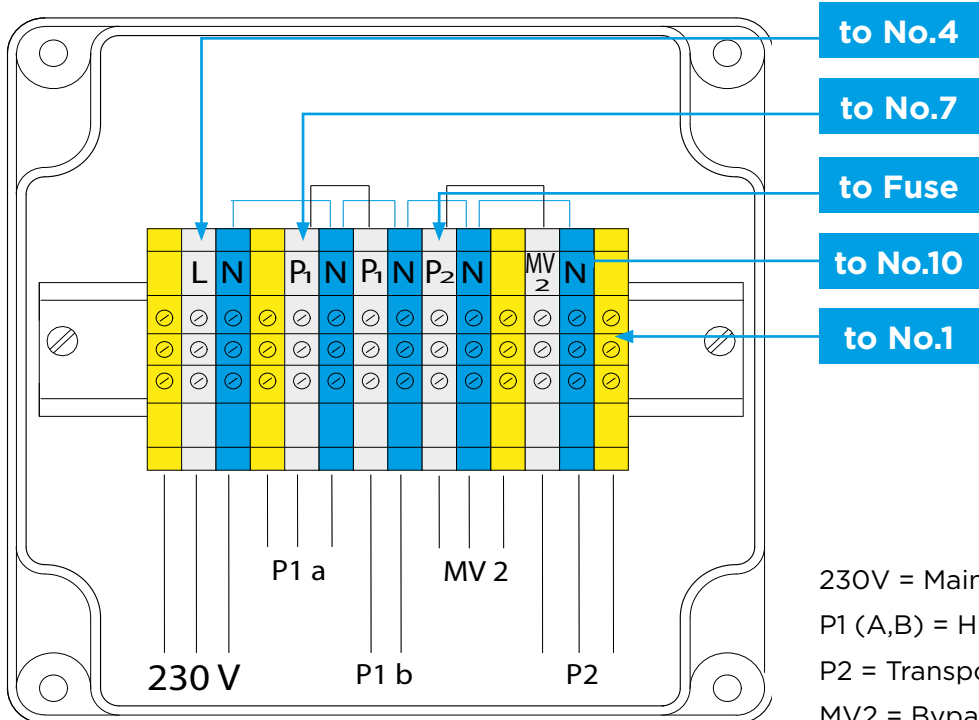

230V = Main cable
 P1 (A,B) = High pressure pump
 P2 = Transport pump
 MV2 = Bypass solenoid

Flow Diagrams

Key:

 Flow control/nozzle

 Solenoid valve

 Pump

 Drain

 Check valve

 Pressure switch

 Flow direction

 Flow switch

RO-Compact 1:

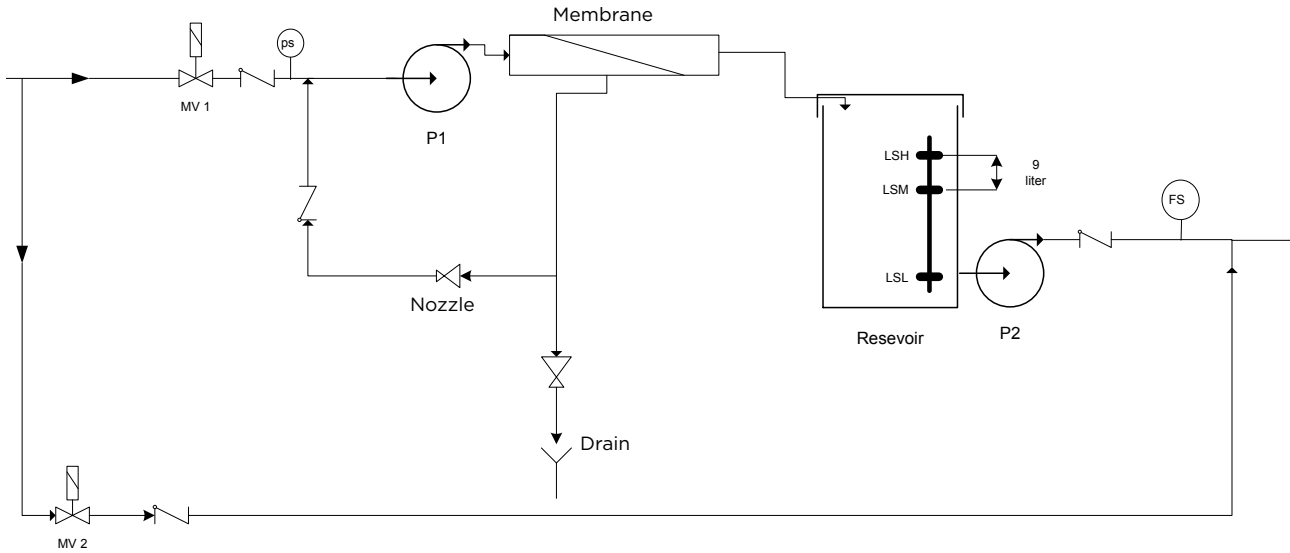

RO-Compact 1 no bypass:

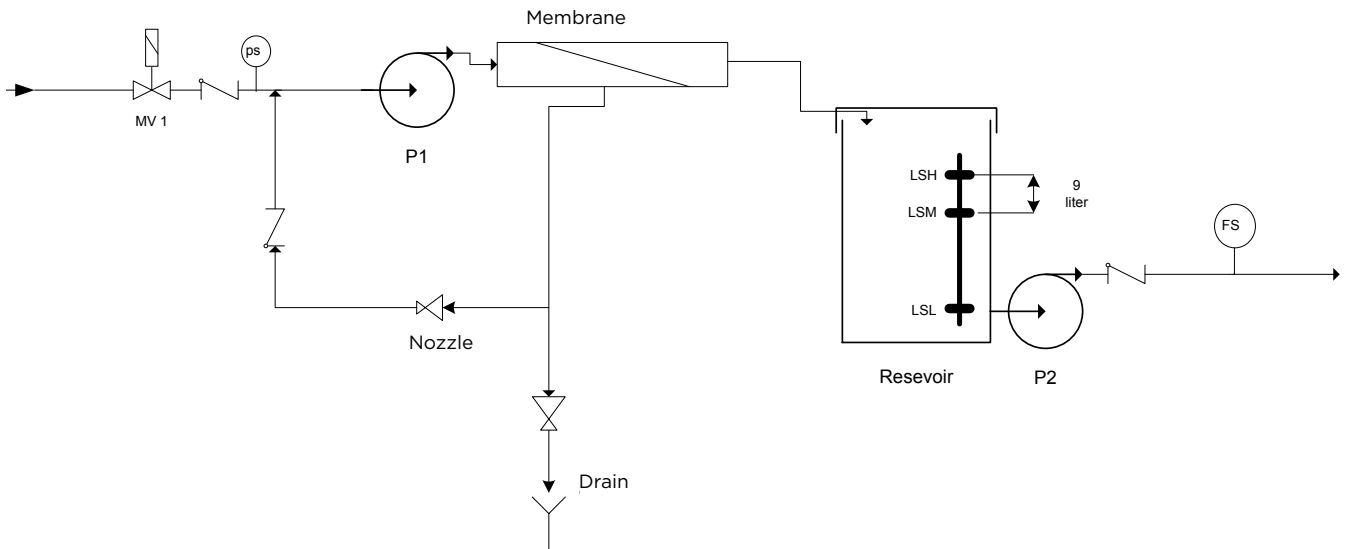

RO-Compact 2:

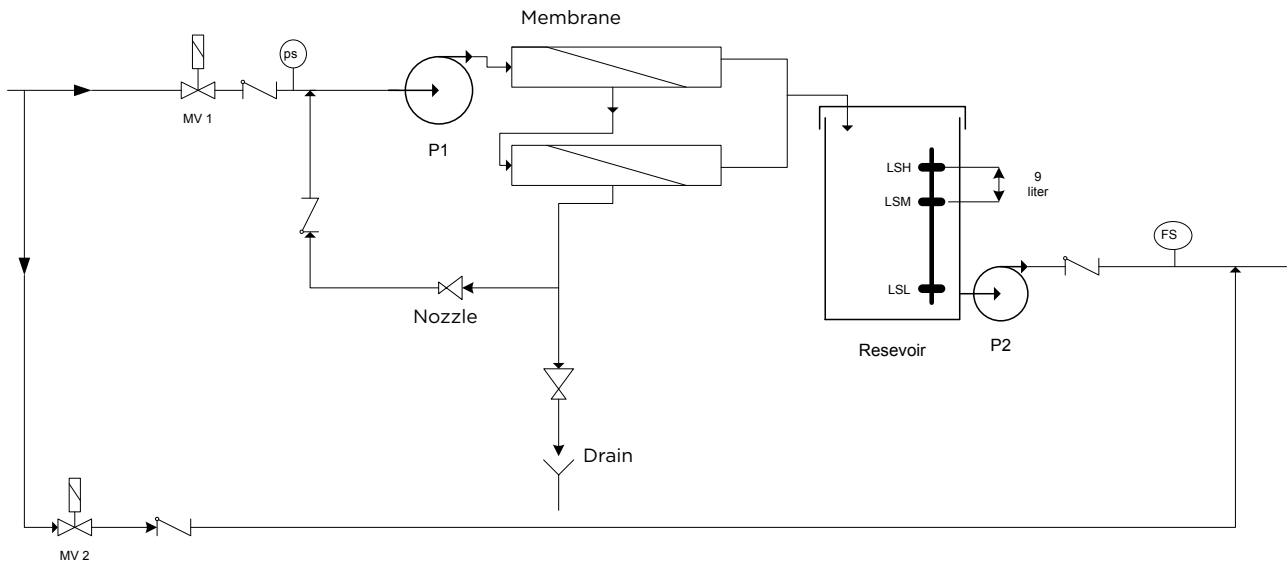

RO-Compact 2 no bypass:

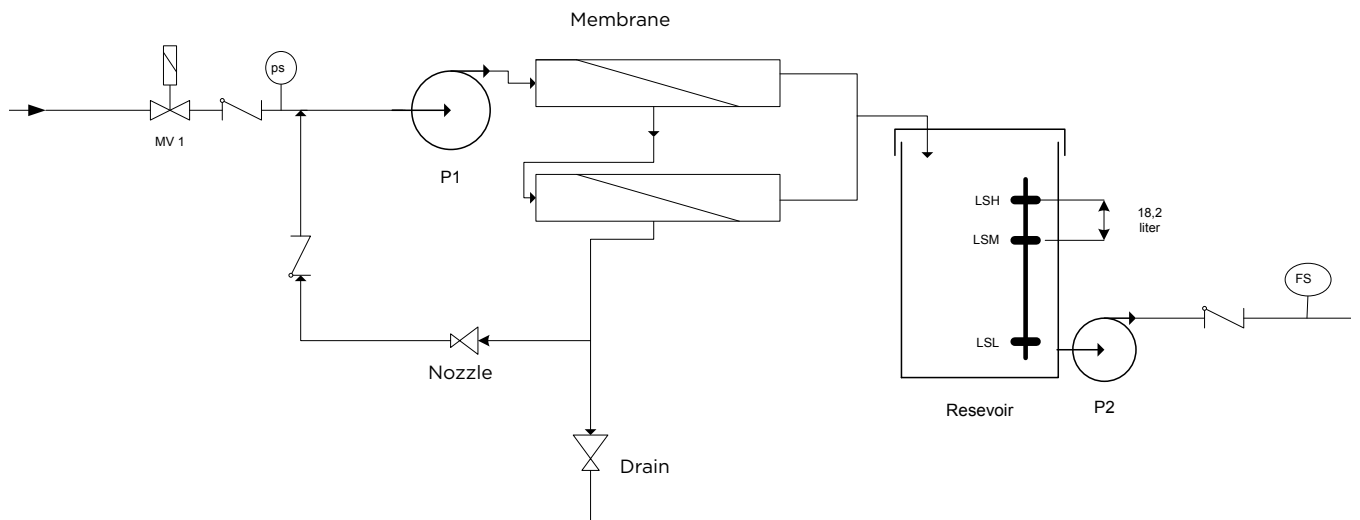

RO-Compact 3:

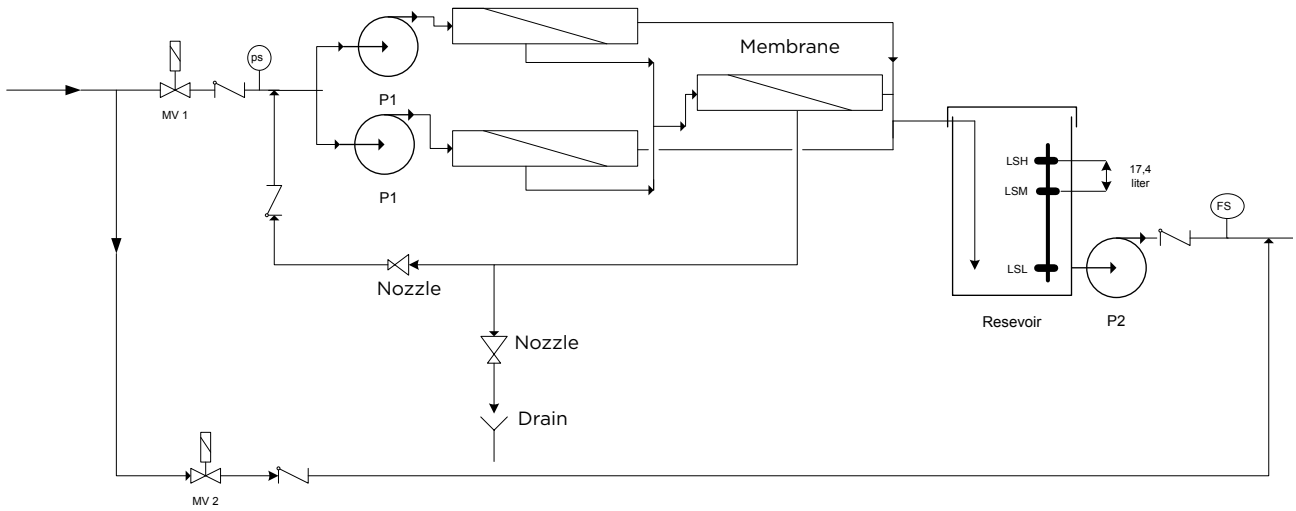

RO-Compact 3 no bypass:

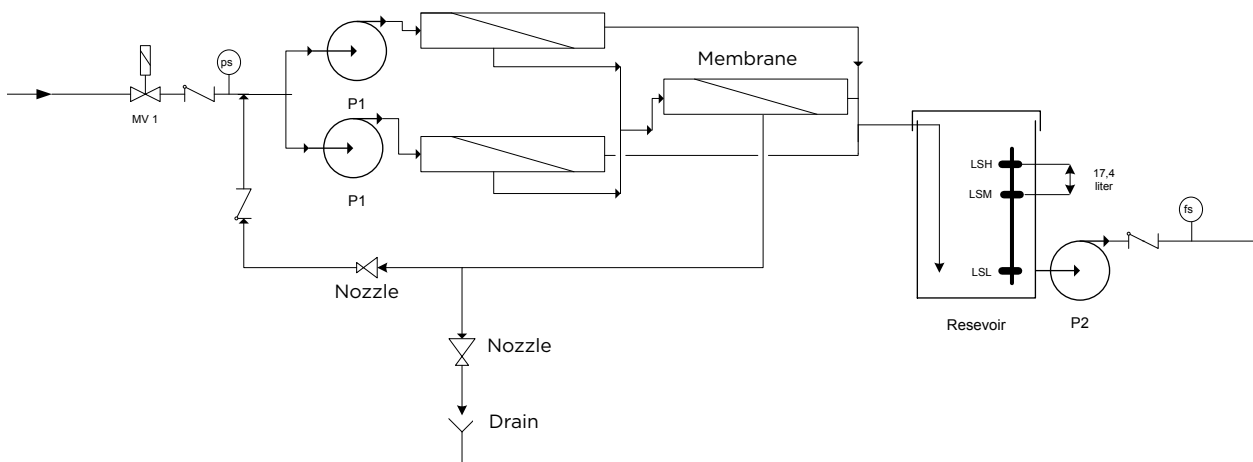

Dimensions

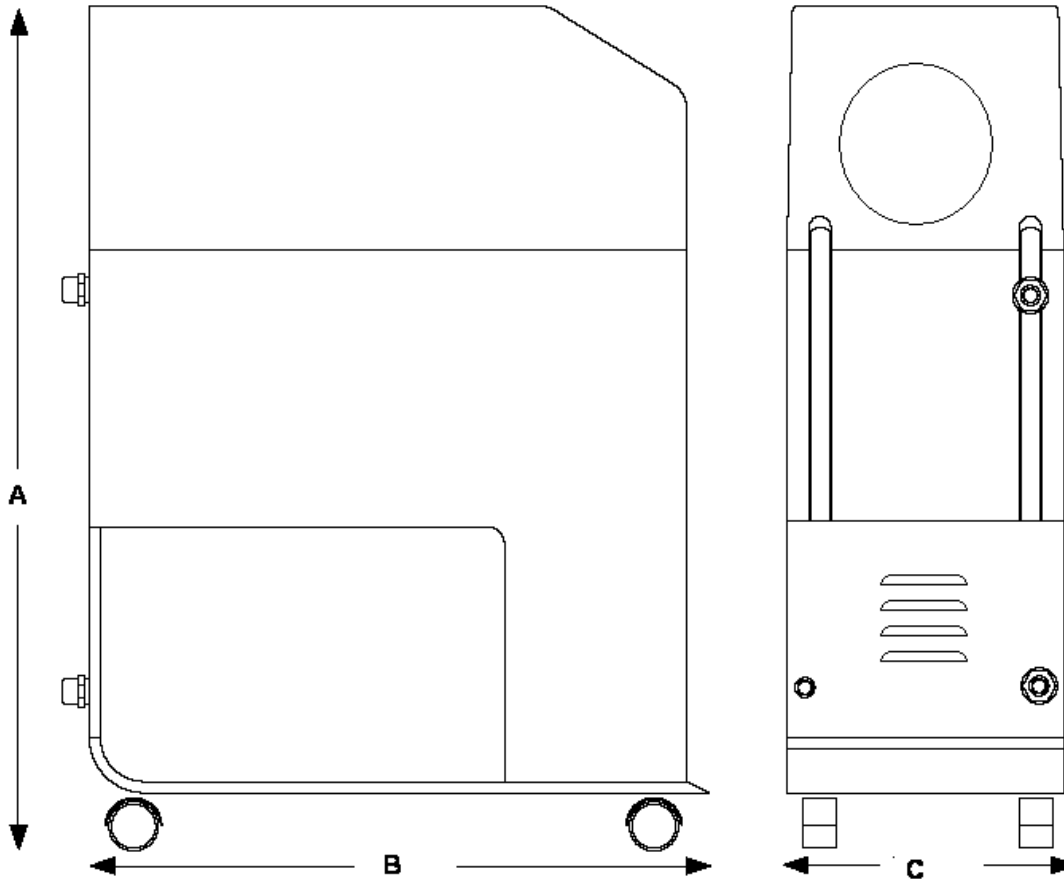

	RO-Compact 1	RO-Compact 2	RO-Compact 3
Height mm	760	700	700
Depth mm	560	580	580
Width mm	250	460	460



EC Declaration of Conformity
Machinery Directive 2006/42/EC Annex II A

ORIGINAL

Company name: Kinetico Denmark Aps
Sandvadsvej 7
4600 Køge
Denmark

We, Kinetico, hereby declare that the following machinery:

Machine/Type: Kinetico RO Compact Series
Description: Reverse Osmosis
Year of Construction: 2014
Serial Number: 1001410 onwards

Complies with the following directive/s:

Machinery Directive 2006/42/EC
EMC Directive 2004/108/EC

Place of Revision: Køge
Date of Revision: 25th of June 2015

A handwritten signature in black ink, appearing to read 'Hadi Mattisen', written over a horizontal line.

HADI MATTISEN
GENERAL MANAGER, KINETICO DENMARK APS



Kinetico International Division, Sandvadsvej 7, Koge, DK - 4600
www.kinetico.eu

© Kinetico 2016.