

→ Kinetico

Premier Plus (Ref.903102)

Water softener without electricity

DESCRIPTION

Compact water softener without electricity. E-MAX technology to guarantee greater savings and lower salt consumption. It combines maximum performance with a compact design, designed to cover all the needs of a home.

FEATURES

RESIN VOLUM (liters)	2 x 11
PRESSURE (max. - min.)	6 - 1,8 bar
TEMPERATURA (max. - min.)	48 - 2 °C
WORK FLOW	1,8 m³/h
WORK MAXIMUM FLOW	2,7 m³/h
CONNECTIONS	3/4"
SALT CAPACITY	25 kg
POWER SUPPLY	No
BY-PASS	Yes
WORKING SYSTEM HIGH VOLUME EFFICIENCY	Yes
SALT DEPOSIT CAPACITY	25 kg salt tablets
EXCHANGE CAPACITY	35° HF/m³
WATER CAPACITY DECALCIFIED AT 300 ppm	1166 L



Compact water softener without electricity. E-MAX technology to guarantee greater savings and lower salt consumption. It combines maximum performance with a compact design, designed to cover all the needs of a home.



E-Max Technology: combines incomparable efficiency and performance to prevent limescale formation in an optimal and long-lasting way.



Quiet Drive Technology: Thanks to their precision valve, Kinetico water softeners are among the most quiet water softeners on the market.

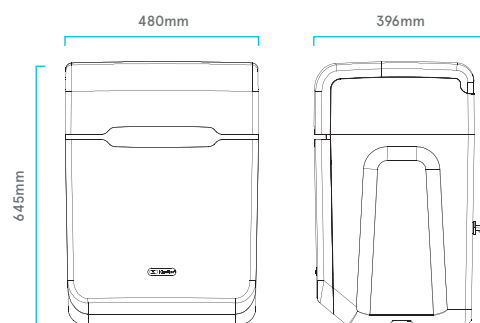

WLG (B-60326279), is member of the Water Quality Association.



ACREDITED BY ENAC
Certif. nº 34/5200/14/0712

The trading of water treatment and household appliances as well as designing and teaching of non-official training courses related with its technology are certified and comply with the UNE-ISO-9001 far WLG (B-60326279).



WLG (B-60326279) is an Aqua España member, who belongs Aqua Europa (Federation of European nation associations).



WLG (B-60326279), has the rights granted for Authorized Economic Operator with number ESAE0F18000008U6 and 13/02/2018 as a date of entry of the authorization.