

columbia.  
aqua

FC-750-ROP  
FC-750-F  
FC-750-UF

---

**MT**

---

**Technical Manual  
Service Booklet**

---





















# MT

## INDEX

1. PRINCIPAL CHARACTERISTICS	4
2. TECHNICAL CHARACTERISTICS	6
3. HOW TO GET WATER FROM YOUR DISPENSER	11
4. IDENTIFYING THE MANAGEMENT AND CONTROL COMPONENTS	11
5. USER INTERFACE	12
6. HOW TO ACCESS THE FILTERS	13
7. WARRANTY	14
8. RECORDING SHEET FOR THE INSTALLATION AND START UP OF THE EQUIPMENT. TECHNICIAN	15
9. SERVICE BOOKLET. USER	16
10. NOTES	18

# 1. PRINCIPAL CHARACTERISTICS

		ROP	F	UF
	<b>DIRECT ACCESS</b> Ease of access and maintenance	•	•	•
	<b>COLUMBIA FILTERS</b> Exclusive filters Maximum hygiene and security	•	•	•
	<b>CAPSULATED MEMBRANE</b> Membrane Installed. Maximum hygiene	•		
	<b>REMINERALIZER</b> Post-filter that adjusts the pH	•		
	<b>CLICK</b> Rapid and highly secure connections	•	•	•
	<b>PRESSURE PUMP</b> Better production and performance	•		
	<b>SOLENOID VALVE</b> Immediate Control. Safety net included.	•		
	<b>REVERSE OSMOSIS</b> Equipment with reverse osmosis system and pump			
	<b>REVERSE OSMOSIS</b> Equipment with reverse osmosis system and pump	•		
	<b>FILTER</b> Equipment with filtration system		•	
	<b>ULTRAFILTRATION</b> Equipment with ultrafiltration system			•
	<b>COLD</b> Cold water production	•	•	•
	<b>HOT</b> Hot water production	•	•	•
	<b>SAVE</b> Safety system for hot water	•	•	•
	<b>AMBIENT</b> Production of room temperature water Heat disabler	•	•	•
	<b>LED</b> LED multifunction information system	•	•	•
	<b>ANTIBACTERIA</b> Protector for faucet outlets made of antibacterial plastic. Removable and washable	•	•	•

	<b>ROP</b>	<b>F</b>	<b>UF</b>
 <p><b>TOP TABLE</b> Desktop equipment ideal for small offices</p>	•	•	•
 <p><b>ENERGY SAVE</b> Energy saving system. A brightness sensor leaves part of the fountain in "stand by" during the night to reduce power consumption</p>	•	•	•

## 2. TECHNICAL CHARACTERISTICS

Application	
Water treatment	<ul style="list-style-type: none"> <li>• Reverse osmosis (ROP Model)</li> <li>• Filtration (F Model)</li> <li>• Ultrafiltration (UF Model)</li> </ul>
Uso	<ul style="list-style-type: none"> <li>• Improves the characteristics of potable water (that complies with the requirements of the EU directive on Water intended for human consumption 98/83 or its national transpositions on the various member states of the European Community).</li> </ul>

### Modification for reduction or intake

ROP Model	<ul style="list-style-type: none"> <li>• Water treatment through reverse osmosis is able to reduce the concentration of salts and other substances in high percentages.</li> <li>• Minimum reduction* of certain components and parameters:               <ul style="list-style-type: none"> <li>Sodium – 90 %</li> <li>Calcium – 90%</li> <li>Sulphates – 90%</li> <li>Chloride – 90%</li> <li>Overall hardness – 90%</li> <li>Conductivity – 90%</li> </ul> </li> </ul> <p>(*) Based on the characteristics of water to be treated (at the outlet of the membrane). These values may vary depending on the type of post-filter used in the equipment.</p>
-----------	---

### F Model

- The treatment of water through filtration retains all suspended particles that have a diameter larger than 5 microns.
  - The carbon filter reduces\* the flavour and smell of the water, as well as its organic components.
- (\*) Based on the characteristics of the water to be treated.

### UF Model

- This equipment comprises a first Filtration stage.
  - The treatment of water through Ultrafiltration is able to retain suspended particles that have a diameter between 0,1 and 0,0001 microns.
- (\*) Based on the characteristics of the water to be treated.

Operational Limits			
	ROP	F	UF
Pressure (max. / min.)	2,5 bar (250 kPa) 1 bar (100 kPa)	5 bar (500 kPa) 1 bar (100 kPa)	5 bar (500 kPa) 1 bar (100 kPa)
TDS (max.)	2000 ppm	-	-
Temperature (max. / min.)	40°C – 2°C	40°C – 2°C	40°C – 2°C
Hardness (max.)	15°HF**	-	-
Technical data			
Control Type:	Level switch. Inlet Solenoid Valve. Cold Water Thermostat. Hot Water Thermostat.	Cold Water Thermostat. Hot Water Thermostat.	Cold Water Thermostat. Hot Water Thermostat.
Security System:	Hot water security shield. Anti-spill Float valves.	Hot water security shield. Anti-spill Float valves.	Hot water security shield. Anti-spill Float valves.
Inlet connection:	1/4"	1/4"	1/4"
Drainage Connection:	1/4"	-	-
Wall adapter:	3/8"	3/8"	3/8"
Drain saddle:	40 mm clamp for the drainage tube	-	-

<b>Treatment:</b>	1 Combined Post-filter (Sediments - Carbon) 1 RO 80 GPD Membrane 1 Postfilter to adjust pH	1 Sediment Pefilter 1 Carbon Prefilter	1 Sediment Pefilter 1 Carbon Prefilter 1 Ultrafiltration cartridge
-------------------	---	---	--

**Pre and Postfilter Connection:**

Inlet: 1/4" spike  
 Outlet: 1/4" spike  
**Membrane Connection**  
 Inlet: 1/4" spike  
 Outlet (RO): 1/4" spike  
 Rejection (R): 1/4" spike

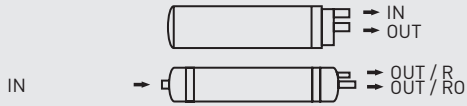

**Dimensions:** (A x B x C) 1100 x 260 x 347  
**Weight:** 31 kg

**TOTAL TANK VOLUME**

**Cold water tank:** \*4 liters. It is reduced to 3,2 liters once a floating valve is incorporated.  
**Hot water tank:** 1,8 liters

**Power Supply** 220 – 240 Vac

**REFRIGERATION SYSTEM**

**Compressor :** 1/11 CV sealed  
**Compressor's Power:** 120 W  
**Capacitor:** Capillary type  
**Refrigerating gas:** R134A  
**Temperature control:** Capillary thermostat

**HEATING SYSTEM**

**Heater:** Band heater  
**Heater's Power:** 430 W  
**Temperature Control** Bi-metal auto-buildable  
**Overheating Protection:** Bi-metal auto-buildable

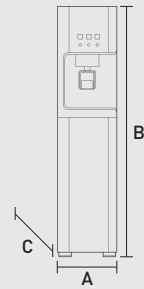

**HYDRAULIC SCHEME – ROP MODEL**

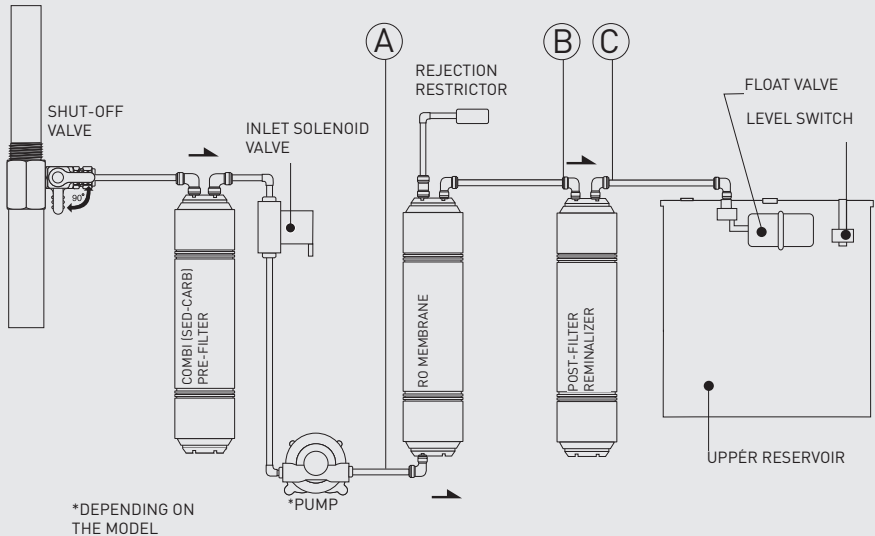

HYDRAULIC SCHEME - F MODEL

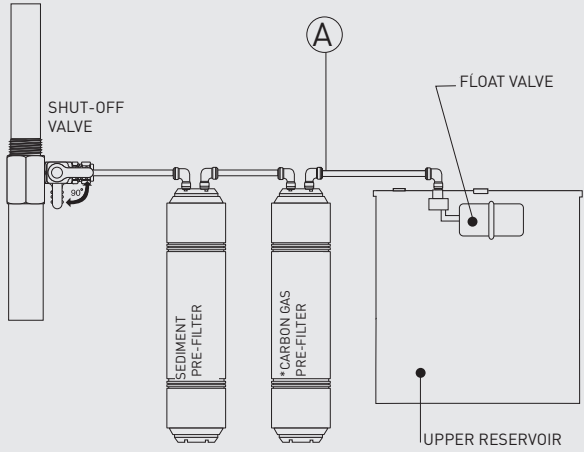

HYDRAULIC SCHEME - UF MODEL

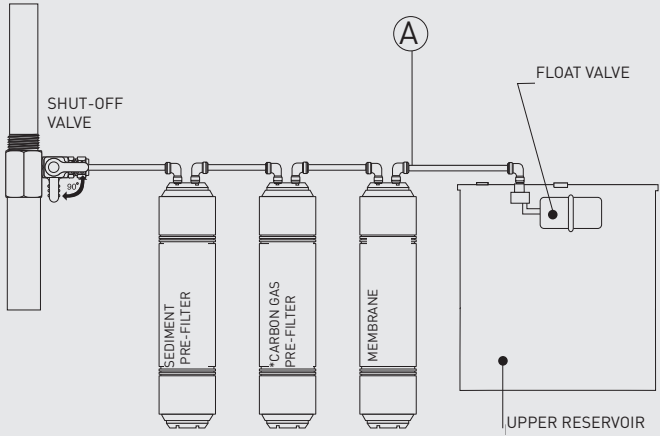



HYDRAULIC SCHEME – RO MODEL

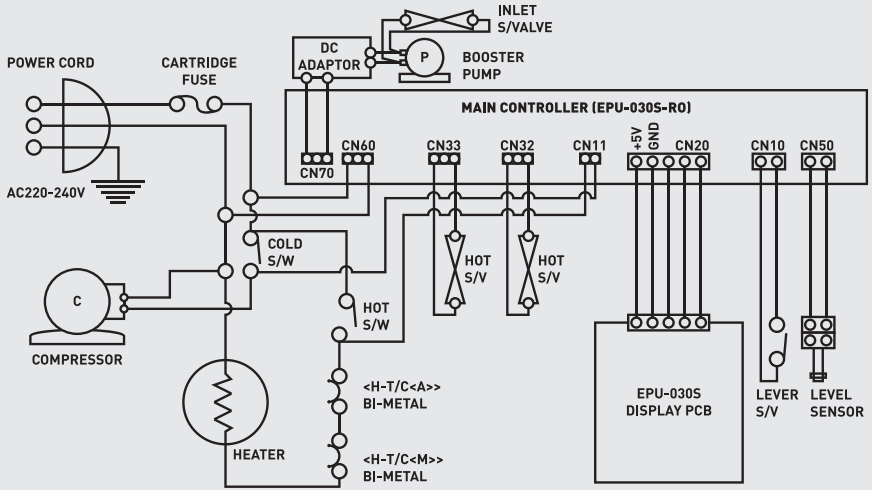

ELECTRIC SCHEME – UF AND F MODEL

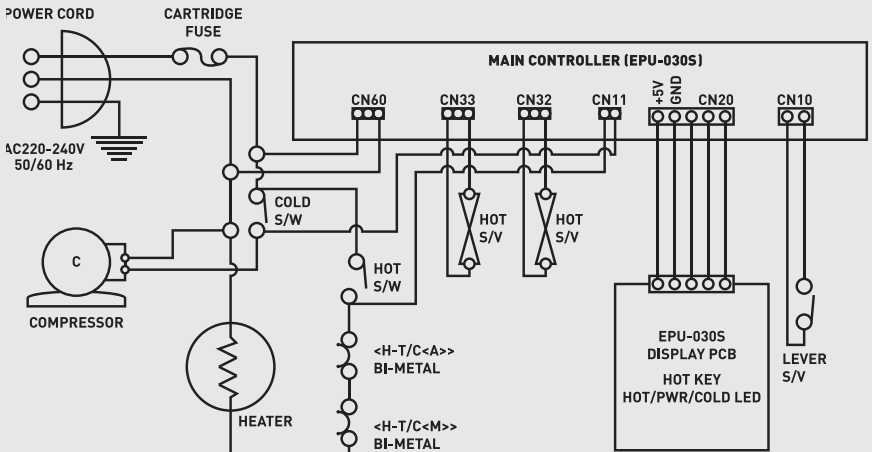

HYDRAULIC CONNECTION SCHEME - RO MODEL

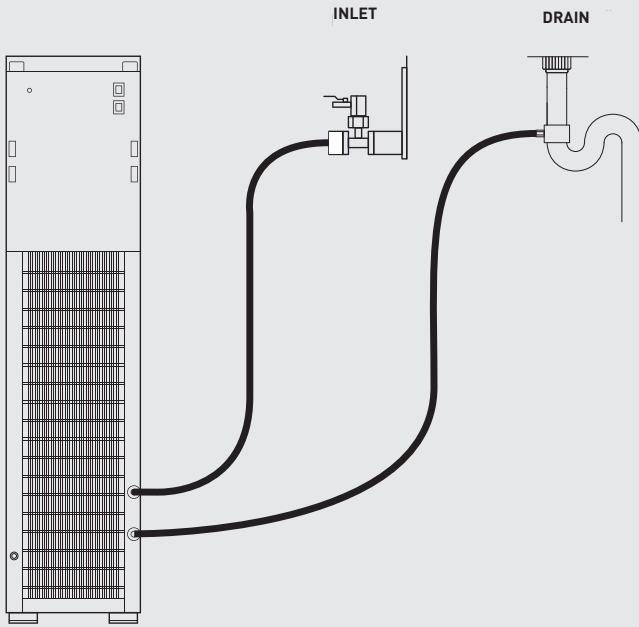

U AND UF MODELS HYDRAULIC CONNECTION SCHEME

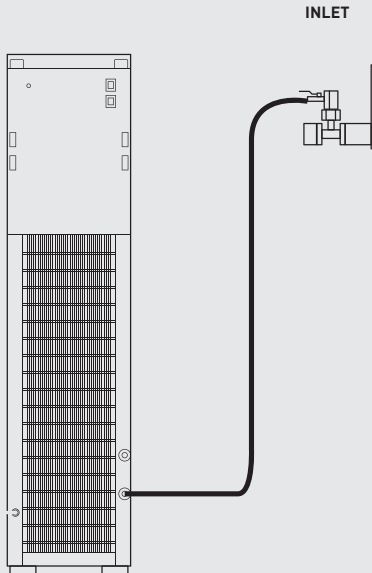

### 3. HOW TO GET WATER FROM THE COOLER

- To get cold water: Press with the cup the lever situated below the cooler so that cold water begins to flow (1).
- To get hot water: Press the upper security HOT/WARM button (image 2, position 1) and see how the red light begins to flicker, afterwards press against the lever with your cup (image 2, position 2) so that the water begins to flow.
- To get warm water: Press the upper security HOT/WARM button (image 2, position 1) and see how the red and green lights begin to flicker, afterwards press against the lever with your cup (image 2, position 2) so that the water begins to flow.

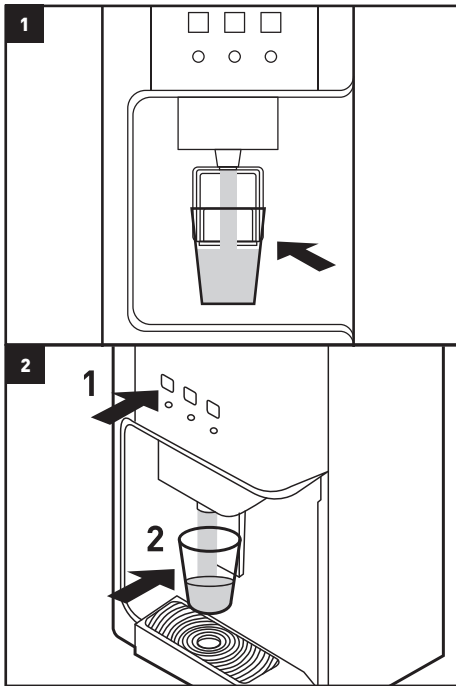

- Dispensing nozzle: this can be disconnected to be cleaned periodically.
- Dispensing lever: press this button to extract cold water, or hot water if you have previously pushed the HOT button.
- Drip tray: Periodically remove the tray to empty it of possible drips after water withdrawals, in order to prevent overflow. To do this, hold the tray with both hands and pull it back slightly.
- Rear hot water switch HOT S/W: to activate the heating system in order to obtain hot water, turn the rear (HOT) switch ON.
- Rear cold water switch COLD S/W: to activate the cooling system in order to obtain cold water, turn the rear (COLD) switch ON.
- Adjusting the temperature of cold water: adjust the temperature of cold water through the rear thermostat. It can be set between 3°C (-°C) and 10°C (+°C).
- Accessing the filters: Extract the drip tray by pulling it and afterwards remove the bolt situated over the lid that remains uncovered once the drip tray has been pulled away. Grasp the lower front cover with both hands and separate it from the equipment while pulling it gently towards the bottom (see point 6).

### 4. IDENTIFYING THE MANAGEMENT AND CONTROL COMPONENTS

- HOT/WARM water security button: press this button before using the water dispenser for hot water. By pressing this button twice, you activate the warm water mode which mixes cold and hot water. This button also activates the "energy saving" mode (see the following point).
- "Energy saving" indicator: this equipment includes a brightness sensor. When the "saving" mode is activated, the equipment will disconnect the heating system during the evening when the surroundings of the equipment are dark. To deactivate the "saving" mode, press the HOT/WARM button for 5 seconds.

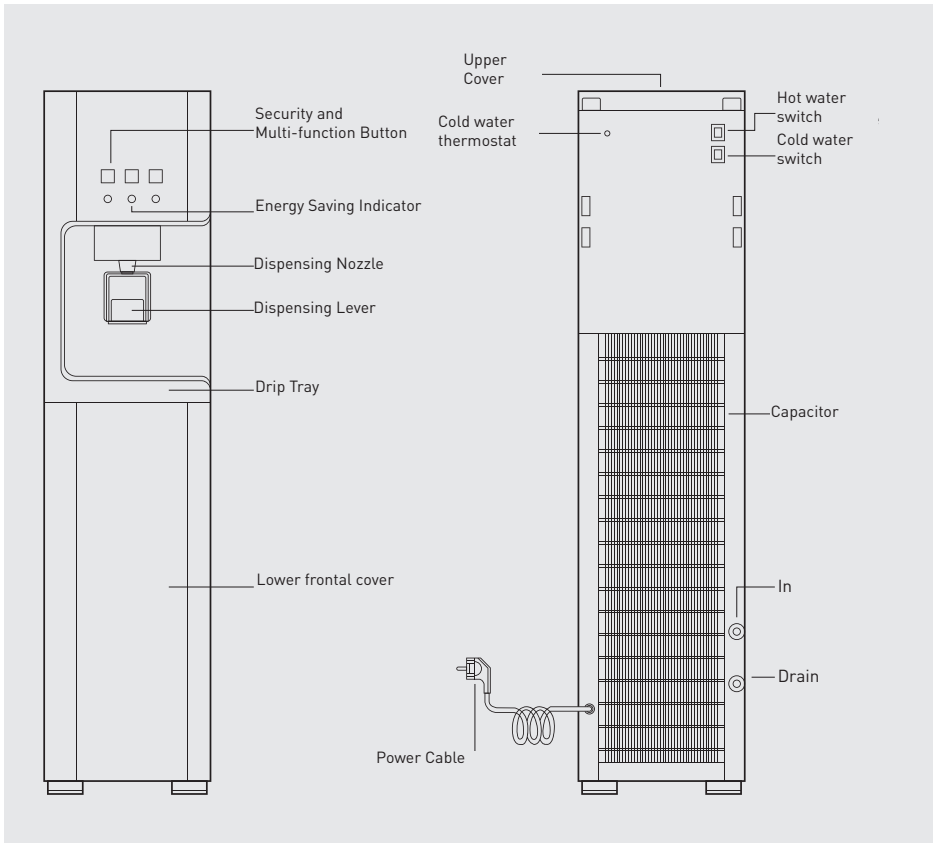

## 5. USER INTERFACE

The device has three status indicators on the front. All the lights will be off while the equipment is not plugged into its power supply (image 3).

The green light below the COLD button indicates that the rear device switch (COLD) is in the ON position and therefore the cooling system is activated.

The green and/or red lights that are on with low intensity indicate that the energy saving system is activated which allows the equipment to work at full capacity while its surroundings are illuminated and, once it is dark (at night) it switches the equipment to energy saving mode by deactivating the water heating system (image 4).

The red light below the HOT / WARM button indicates that the rear switch of the equipment (HOT) is in the ON position and therefore the heating system is activated. This light will flash while water is being dispensed (image 4),

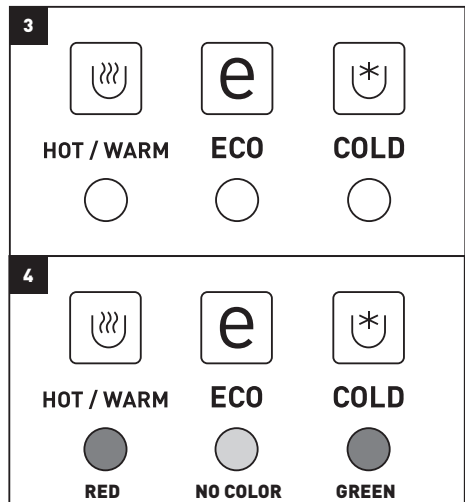

## 6. HOW TO ACCESS THE FILTERS

Extract the drip tray by pulling it and afterwards remove the bolt situated over the lid that remains uncovered once the drip tray has been pulled away.

Grasp the lower front cover with both hands and separate it from the equipment while pulling it gently towards the bottom.

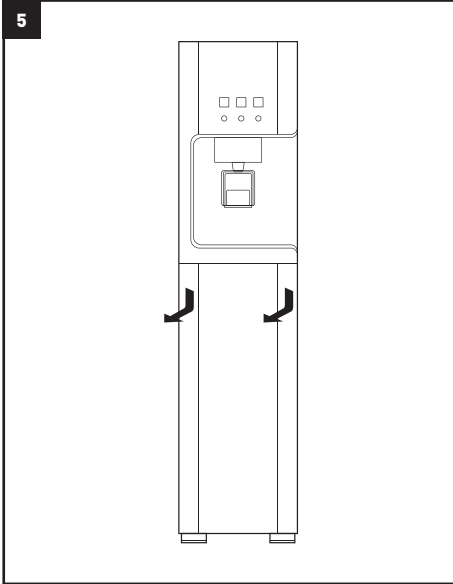

## 17. WARRANTY

### EQUIPMENT WARRANTY ADDRESSED TO THE END-USER:

The distributor guarantees the equipment for a period of two years for any lack of conformity detected and as pursuant to RD 1/2007 of 16 November (Consolidated text of the General Law for the Defence of Consumers and Users). The warranty provides for the reparation and substitution of defective pieces by personnel authorised by the Distributor or the Technical Assistance Service (TAS), wherever they have been installed or in their workshops. The warranty covers any labour and shipment fees that may be incurred.

IF/PEU/PAM\* is exempt from this warranty if the parts are subject to natural wear, lack of maintenance, blows or other lack of conformity that result from the improper use of the equipment or its inadequate use considering the operational limits indicated by its manufacturer. The warranty is also invalidated in cases of improper manipulation and use of the equipment, or when the equipment has been modified or repaired by personnel not employed by the distributor or the official TAS. The parts replaced under warranty will remain property of IF/PEU/PAM\*.

IF/PEU/PAM\* responds for the lack of conformity of the equipment when there are issues with the origin, identity or suitability of the products, in accordance with their nature and purpose.

Taking into account the characteristics of the equipment, if the warranty is to cover any lack of conformity, compliance with the technical installation and operation conditions of this warranty sheet is essential; as is a copy of the invoice or purchase ticket. If these conditions are not fulfilled, it may lead to the invalidation of the warranty, taking into account the equipment's purpose and the conditions and operating limits within which it must operate.

The distributor guarantees that the equipment installed is suitable in particular for the improvement of the quality of the water to be treated, based on the characteristics of the equipment and all applicable laws.

The installer and/or distributor guarantees the correct installation and implementation of the equipment as indicated by the manufacturer and applicable law and will also respond for any lack of conformity that may result from the incorrect application, instalment or implementation of the equipment.

For any warranty claims it is necessary to present the purchase invoice. The 2-year period is calculated from the day the equipment was purchased from the distributor.

If during the warranty period your equipment presents any issues, contact your distributor.

**If an equipment with osmosed water is installed, IF/PEU/PAM**

**\* will not be responsible for any damages, malfunctioning and consequences of these latter if they are produced by the characteristics of the water.**

**\*IF/PEU/PAM = IONFILTER / PURICOME EUROPE/ PURICOM AMERICA**

### The equipment was installed and functions satisfactorily for the client and for the record:

\*Pre-treatment of the equipment:

\*Inlet hardness of the equipment [oF]

\*Inlet TDS of the equipment [ppm]

\*Inlet pressure of the equipment [bar]

### Results of the Installation Data Sheet and Start-up:

CORRECT

OTHERS

The owner of the equipment has been informed adequately and clearly of the use, manipulation and maintenance that the equipment requires to guarantee its correct operation and the quality of the water produced. For this reason, we offer you a maintenance contract.

### \*Ref. Maintenance Contract:

ACCEPTS the maintenance contract

DOES NOT ACCEPT the maintenance contract

If you need information, or if you need to communicate any damages, maintenance requests or request the intervention of a technician, first read the operational, detection and problem shooting sections of this manual and get in touch with the distributor or the company that sold your equipment.

AUTHORISED COMPANY AND/OR INSTALLER: (date and signature)

### NOTE FOR THE COMPANY AND/OR THE AUTHORISED TECHNICIAN/INSTALLER:

The data marked with (\*) must be filled by the installing technician

Serial number:

**18. RECORD SHEET FOR THE INSTALLATION AND COMMISSIONING OF THE EQUIPMENT. TECHNICIAN**

**NOTES FOR THE TECHNICIAN/INSTALLER:** Read this Manual carefully. If you have any doubts, get in touch with the Technical Assistance Service (T.A.S.) of your distributor. The data marked with (\*) must be filled by the installing technical and transcribed in the WARRANTY SHEET. This sheet must be preserved by the installer/distributor and may be required by IF/PEU/PAM\* for the purpose of improving after-sale and customer service. The technician that performs the installation and set-up of the equipment must be in possession of the appropriate skills.

**COMMENTS:**  
 Results of the installation and set-up:  
 CORRECT (equipment installed and functioning correctly. Water produced can be used).  
 OTHERS: \_\_\_\_\_  
 \_\_\_\_\_

Serial number: \_\_\_\_\_  
 \_\_\_\_\_  
 \_\_\_\_\_

**Identification of the Authorized Technician/Installer**  
 Company and/or installer, date and signature  
 \_\_\_\_\_  
 \_\_\_\_\_

**DATA OVER THE APPLICATION OF THE EQUIPMENT**  
 Source of the water to be treated:  
 Public Supply Network  
 \*Pre-treatment to the equipment \_\_\_\_\_  
 \*Inlet hardness RO equipment [oF] \_\_\_\_\_  
 \*Inlet TDS in RO equipment [ppm] \_\_\_\_\_  
 \*Inlet Pressure in RO equipment [bar] \_\_\_\_\_  
 \*Chloride Concentration [ppm] \_\_\_\_\_

**Confirmation of the Equipment's Owner**  
 I have been clearly informed of the use, manipulation and maintenance that the installed equipment requires and I have been offered a maintenance contract and informed of how to contact Customer Service if I need information, if I need to notify any damages or malfunctioning, request a maintenance service or request the intervention of a technician.  
 Comments: \_\_\_\_\_  
 \_\_\_\_\_

**Installation Check-List**  
 Cleaning of carbon filters.  
 Cleaning of carbon post-filters.  
 Sanitization according to the described protocol  
 Revision and Fitting  
 Verifying of the pressurized system  
 TDS of the produced water [ppm] \_\_\_\_\_  
 The customer has been clearly informed of the use, manipulation and maintenance that the equipment requires to guarantee its correct operation and the quality of water procured. Taking into account the importance that a correct maintenance of the equipment holds to guaranteeing the quality of the water produced, the owner must be offered a maintenance contract carried out by properly trained technicians

**\*Ref. Maintenance Contract** \_\_\_\_\_  
 ACCEPTS the maintenance contract  
 DOES NOT ACCEPT the maintenance contract  
 Model / Ref. \_\_\_\_\_  
 Owner (Mr/Ms) \_\_\_\_\_  
 \_\_\_\_\_  
 Street: \_\_\_\_\_  
 \_\_\_\_\_  
 Phone No.: \_\_\_\_\_  
 \_\_\_\_\_  
 Population: \_\_\_\_\_  
 Province: \_\_\_\_\_ ZIP: \_\_\_\_\_

Date and Signature  
 \_\_\_\_\_  
 \_\_\_\_\_

**19. EQUIPMENT INSTALLATION AND COMMISSIONING RECORD SHEET. TECHNICIAN**



DATE	TYPE OF SERVICE	NAME, SIGNATURE AND SEAL OF THE AUTHORIZED TECHNICIAN	
/ /	<input type="checkbox"/> SET-UP	TECHNICIAN	
/ /	<input type="checkbox"/> FULL MAINTENANCE	SEAL	
/ /	<input type="checkbox"/> REPARATION		
/ /	<input type="checkbox"/> SANITIZATION		
/ /	<input type="checkbox"/> OTHER		
/ /	<input type="checkbox"/> FULL MAINTENANCE		
/ /	<input type="checkbox"/> REPARATION	SEAL	
/ /	<input type="checkbox"/> SANITIZATION		
/ /	<input type="checkbox"/> OTHER		
/ /	<input type="checkbox"/> FULL MAINTENANCE		
/ /	<input type="checkbox"/> REPARATION	SEAL	
/ /	<input type="checkbox"/> SANITIZATION		
/ /	<input type="checkbox"/> OTHER		
/ /	<input type="checkbox"/> FULL MAINTENANCE		
/ /	<input type="checkbox"/> REPARATION	SEAL	
/ /	<input type="checkbox"/> SANITIZATION		
/ /	<input type="checkbox"/> OTHER		
/ /	<input type="checkbox"/> FULL MAINTENANCE		
/ /	<input type="checkbox"/> REPARATION	SEAL	
/ /	<input type="checkbox"/> SANITIZATION		
/ /	<input type="checkbox"/> OTHER		
/ /	<input type="checkbox"/> FULL MAINTENANCE		
/ /	<input type="checkbox"/> REPARATION	SEAL	
/ /	<input type="checkbox"/> SANITIZATION		
/ /	<input type="checkbox"/> OTHER		
/ /	<input type="checkbox"/> FULL MAINTENANCE		
/ /	<input type="checkbox"/> REPARATION	SEAL	
/ /	<input type="checkbox"/> SANITIZATION		
/ /	<input type="checkbox"/> OTHER		
/ /	<input type="checkbox"/> FULL MAINTENANCE		



**19. SERVICE BOOKLET. USER**

DATE	TYPE OF SERVICE	NAME, SIGNATURE AND SEAL OF THE AUTHORIZED TECHNICIAN	
/ /	<input type="checkbox"/> SET-UP	TECHNICIAN	
/ /	<input type="checkbox"/> FULL MAINTENANCE	SEAL	<input type="checkbox"/> ORDINARY
/ /	<input type="checkbox"/> REPAIRATION		<input type="checkbox"/> EXTRAORDINARY
/ /	<input type="checkbox"/> SANITIZATION		
/ /	<input type="checkbox"/> OTHER		<input type="checkbox"/> WARRANTY
/ /	<input type="checkbox"/> FULL MAINTENANCE		TECHNICIAN
/ /	<input type="checkbox"/> REPAIRATION	SEAL	<input type="checkbox"/> EXTRAORDINARY
/ /	<input type="checkbox"/> SANITIZATION		<input type="checkbox"/> WARRANTY
/ /	<input type="checkbox"/> OTHER		
/ /	<input type="checkbox"/> FULL MAINTENANCE		TECHNICIAN
/ /	<input type="checkbox"/> REPAIRATION	SEAL	<input type="checkbox"/> EXTRAORDINARY
/ /	<input type="checkbox"/> SANITIZATION		<input type="checkbox"/> WARRANTY
/ /	<input type="checkbox"/> OTHER		
/ /	<input type="checkbox"/> FULL MAINTENANCE		TECHNICIAN
/ /	<input type="checkbox"/> REPAIRATION	SEAL	<input type="checkbox"/> EXTRAORDINARY
/ /	<input type="checkbox"/> SANITIZATION		<input type="checkbox"/> WARRANTY
/ /	<input type="checkbox"/> OTHER		
/ /	<input type="checkbox"/> FULL MAINTENANCE		TECHNICIAN
/ /	<input type="checkbox"/> REPAIRATION	SEAL	<input type="checkbox"/> EXTRAORDINARY
/ /	<input type="checkbox"/> SANITIZATION		<input type="checkbox"/> WARRANTY
/ /	<input type="checkbox"/> OTHER		
/ /	<input type="checkbox"/> FULL MAINTENANCE		TECHNICIAN
/ /	<input type="checkbox"/> REPAIRATION	SEAL	<input type="checkbox"/> EXTRAORDINARY
/ /	<input type="checkbox"/> SANITIZATION		<input type="checkbox"/> WARRANTY
/ /	<input type="checkbox"/> OTHER		
/ /	<input type="checkbox"/> FULL MAINTENANCE		TECHNICIAN
/ /	<input type="checkbox"/> REPAIRATION	SEAL	<input type="checkbox"/> EXTRAORDINARY
/ /	<input type="checkbox"/> SANITIZATION		<input type="checkbox"/> WARRANTY
/ /	<input type="checkbox"/> OTHER		
/ /	<input type="checkbox"/> FULL MAINTENANCE		TECHNICIAN





**MT**