

columbia.<sup>®</sup>  
aqua

FC-425-ROP  
FC-425-F  
FC-425-UF

**TECHNICAL/USER MANUAL  
AND SERVICE BOOK**



# USER MANUAL

INDEX	P	
0	Main features	5
1	Unpacking	8
2	Introduction	8
3	Types of dispenser treatments	8
4	Advance warnings	9
5	Equipment operation	10
6	Installation	10
7	Carbon filter rinsing	11
8	System tightness check, stop and start (RO)	11
9	Cleaning and maintenance	11
10	Sanitization procedure	12
11	User interface	13
12	Troubleshooting	14

# TECHNICAL MANUAL

INDEX	P	
1	Technical characteristics	17
2	Identification of management and control components	21
3	How to extract water from the dispenser	22
4	User interface	22
5	How to access the filters	22
6	Periodic maintenance	22
7	Warranty	23
8	Installation record sheet	24
9	Maintenance service	25



# TECHNICAL SHEET

## 0. MAIN CHARACTERISTICS

---



**DIRECT \*/\*\*/\*\***  
**ACCESS**  
EASE OF ACCESS  
AND MAINTENANCE



**COLUMBIA FILTERS \*/\*\*/\*\***  
EXCLUSIVE FILTERS MAXIMUM  
SAFETY AND HYGIENE



**COLUMBIA\***  
**MEMBRANE**  
MAXIMUM HYGIENE



**CLICK \*/\*\*/\*\***  
QUICK CONNECTIONS  
AND MAXIMUM SECURITY



**PRESSURE \***  
**PUMP**  
GREATER PRODUCTION  
AND PERFORMANCE



**SOLENOID VALVE \***  
IMMEDIATE CONTROL



**ROP**  
REVERSE OSMOSIS \*  
EQUIPMENT WITH REVERSE  
OSMOSIS SYSTEM AND PUMP



**FILTER \*\***  
EQUIPMENT  
WITH FILTRATION SYSTEM



**ULTRAFILTRATION \*\*\***  
EQUIPMENT WITH  
ULTRA-FILTRATION SYSTEM



**COLD \*/\*\*/\*\***  
PRODUCTION OF  
COLD WATER



**HOT \*/\*\*/\*\***  
PRODUCTION OF  
HOT WATER



**AMBIENT \*/\*\*/\*\***  
WATER PRODUCTION  
AT AMBIENT TEMPERATURE

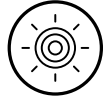

**LED \*/\*\*/\*\***  
INFORMATION SYSTEM  
MULTIFUNCTION BY LED



**SAFE \*/\*\*/\*\***  
SECURITY SYSTEM  
FOR HOT WATER

\* FC-425 ROP  
\*\* FC-425 F  
\*\*\* FC-425 UF



*Keep this manual, which includes the service book and warranty sections, in order to provide you with better after-sales service.*

## SECURITY INSTRUCTIONS

Below are safety warnings and instructions to prevent injury to the user and to prevent material damage to the user's environment. However, it is important to take the necessary precautions and proceed with care during the installation, maintenance, cleaning and handling of the appliance.

### Children/adults/pets

- The device may not be used by children under 8 years of age or by people with reduced physical, sensory or mental capacity, as well as by people without experience or knowledge unless they are supervised or receive instructions on how to use the device safely and have understood the potential risks of using it.
- Children must not play with this appliance.
- Do not allow children to clean or maintain the appliance without supervision.

### Warning. Choking Hazard!

Do not allow children to play with the packaging/plastic or with parts of the packaging, as they could become entangled or cover their heads with them and suffocate.

Keep packaging, plastic and packaging parts out of the reach of children.

### Mounting. Warning

Risk of electric shock/fire/material damage/damage to the device!

If the appliance is not installed correctly, it can lead to dangerous circumstances. Make sure that the following conditions are met:

- The mains voltage in the socket must correspond to the voltage rating specified on the device (nameplate).
- The mains plug and the socket with a protective contact must match and the grounding system must be correctly installed.
- The installation must have a suitable cross section.

The mains plug must remain accessible at all times. If this is not possible, in order to comply with the relevant safety regulations, a switch (double pole switch) must be permanently integrated into the installation, according to the regulations on electrical installations.

If the power cord of the appliance is modified or damaged, it may cause electric shock, short circuit or fire due to overheating.

The mains cable must not be bent, crushed or modified, nor must it come into contact with sources of heat.

The use of extension cords or power strips could cause a fire due to excessive heating or a short circuit. Connect the appliance directly to a properly installed socket with earth connection. Do not use extension cords, power strips or multiple connectors.

**Warning. Risk of injury!**

- The appliance is very heavy. Lifting the unit could cause injuries. Always lift the appliance with help.
- If the tubes and mains cables are not routed correctly, there is a risk of a disconnection, which could cause injury. Route tubes and cables in such a way that there is no risk of disconnection.

**Attention!. Danger of material damage/damage to the device**

- If the water pressure is too high or too low, the appliance may not work properly. In addition, material damage or damage to the device could occur. Make sure that the water pressure in the water supply installation is at least 100 kPa (1 bar) and does not exceed 500 kPa (5 bars).
- If the water tubes are modified or damaged, they may cause material damage or damage to the device. The water pipes

must not be bent, crushed, modified or cut.

The use of tubes distributed by other brands to connect the water supply could cause material damage or damage to the appliance. Use only the tubes supplied with the device or original replacement tubes.

**Cleaning/maintenance Warning. Death risk!**

The device works with electricity. There is a risk of electric shock if live components are touched. Therefore, take into account:

- Switch off the device. Disconnect the appliance from the mains (disconnect the plug).
- Never grasp the mains plug with wet hands.
- When disconnecting the plug from the socket, always grasp the plug itself and never the mains cable, as it could be damaged.
- Do not make technical modifications to the device or its components. Any repair or other type of work that the appliance requires must be carried out by our technical service or by an electrician. The same applies to replacing the mains cable (if necessary).
- Replacement mains cables can be ordered by contacting our technical service.

## 1. UNPACKING

It is important that before installation and start-up, check the box and condition of the equipment, in order to guarantee that it has not been damaged during transport.

**!** **Attention: Claims for damage during transport must be submitted together with the delivery note or invoice to your distributor, attaching the name of the carrier within a maximum period of 24 hours after receipt of the merchandise.**

Remove the equipment and accessories from their cardboard packaging, removing the corresponding protections.

**!** **Attention: Dispose of plastic bags properly and keep out of the reach of children, as they can be a danger to them.**

Inside you will find (depending on the model): Water treatment equipment, installation accessories and documentation.

The materials used in the packaging are recyclable and must be discarded in the appropriate selective collection containers or in the specific local center for the recovery of waste materials.

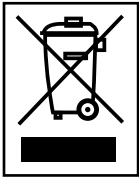

This product cannot be disposed of with normal urban waste. When the useful life of the equipment has ended, it must be delivered to the company or center where you purchased the appliance, or to a Clean Point or specific local center for the recovery of materials, indicating that it has electrical, electronic components and refrigerant gas.

The correct collection and treatment of useless equipment helps to preserve natural resources and also to avoid potential risks to public health.

## 2. INTRODUCTION

This manual describes the characteristics of the F, UF and RO versions. Some models do not have the 3 versions, in case of doubt consult your distributor.

F systems include sediment filtration and activated carbon filtration.

UF systems include sediment filtration, activated carbon filtration, and ultrafiltration membrane. RO systems include sediment filtration, carbon filtration, reverse osmosis membrane, and pH corrector (remine-ralizer) cartridge.

Congratulations. You have purchased one of the best existing water treatment equipment on the market for office use.

This equipment will help you improve the characteristics of the water, providing you with the highest quality water with low mineralization.

Your equipment will provide you with different benefits and advantages:

- It is a physical system that does not use or add chemicals to the water.
- Provides a high quality of water.
- It has a low maintenance cost.
- Ensures high production.

## 3. TYPES OF TREATMENTS OF COLUMBIA AQUA DISPENSERS

Columbia dispensers are available, depending on the model, with different types of water treatment: filtration, ultrafiltration and reverse osmosis.

### 3.1 What is filtration?

#### Sediment filter.

Filtration is the process of separating suspended solids in water through a porous medium, also called a filter. The water passes through the pores of the filter, but the particles with a size greater than the pores of the filter are retained in it, thus giving rise to clearer water. Columbia Dispensers incorporate 5µm filters.

#### Active carbon filter.

Activated carbon is used to remove chlorine from water, as well as to improve the taste, smell and eliminate some organic components thanks to its great capacity as an adsorbent. Columbia Sources incorporate granulated carbon.

### 3.2 What is ultrafiltration?

Ultrafiltration is the system used to completely eliminate viruses and bacteria from water. Ultrafiltration membranes have a porosity between 0.1 and 0.001 µm, which is why they are capable of retaining suspended particles much better.

**This appliance is intended to be used in domestic and similar applications.**

- Personal kitchen areas in stores, offices and other work environments.
- Rural lodgings and by clients in hotels, motels and other residential type environments.
- Bed and breakfast type environments.
- Restaurant services and similar non-retail applications.

More technical information at:  
[www.wtreatmentresources.com/986741NFPW.html](http://www.wtreatmentresources.com/986741NFPW.html)



### 3.3 What is osmosis?

Natural or direct osmosis is the most common in nature, since semi-permeable membranes are part of the vast majority of organisms (for example, plant roots, organs of our own body, cell membranes, etc.).

When two solutions of different concentrations of salts are separated by a semi-permeable membrane, a natural flow of water occurs from the solution of lower concentration to the one of higher concentration. This flow continues until the concentrations on both sides of the membrane equalize.



When it comes to reversing this process and achieving a flow of water with a lower concentration of salts from one with a higher concentration, a sufficient pressure of the water with a higher concentration must be exerted on the membrane to overcome the tendency and natural flow of the system. .

This process is what we call reverse osmosis. Currently, reverse osmosis is one of the best methods to improve the characteristics of water, through a physical system (without the use of chemical products).

The water to be treated exerts pressure on the semi-permeable membrane, so that part of it will manage to pass through the pores of the membrane (osmotic water), while the rest of the water (rejected or with a high concentration of salts) will be diverted towards the drain ( Fig. 1).

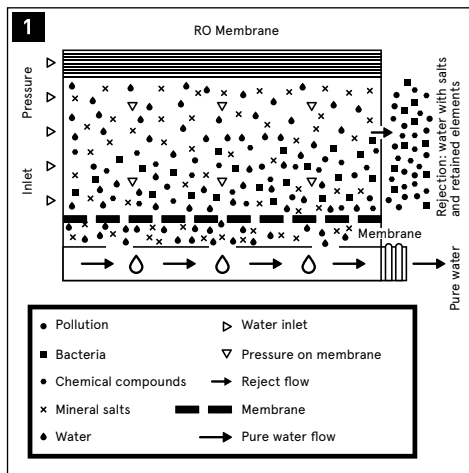

#### 4. PREVIOUS WARNINGS

##### Warnings



- These appliances are supplied with refrigerant gas, ISOBUTANE (R-600a), which is a natural gas with no harmful effects on the environment, but it is flammable.

- The appliance must be transported and moved with the utmost care so that it is not knocked or shaken excessively. Failure to comply with this rule could put the device out of service.

- Keep the ventilation openings of the appliance or the built-in structure, free of obstructions.

- Do not damage the cooling circuit. If the refrigeration circuit is damaged, with possible refrigerant gas leakage, it could create explosion risks caused by sparks or external flames.

- Under no circumstances operate your appliance if it appears to be damaged.

- In the event of a breakdown, contact your Technical

Service, ventilate the room where the appliance is located and avoid flames or work on the appliance.

- For recycling, contact your local waste disposal service or the seller. The appliance must be transported without damaging the refrigeration circuit.

- This appliance is intended to be used in domestic and similar applications such as staff kitchen areas in shops, offices and other work environments; rural and client accommodations in hotels, motels and other residential type settings; bed and breakfast type settings; catering services and similar non-retail applications.

**!** Attention: Read carefully and keep this manual before installing and starting up the equipment. If you have any questions about the installation, use or maintenance of this equipment, contact the technical assistance service (SAT) of your distributor.

**!** Attention: These equipments ARE NOT WATER PURIFICATORS. If the water to be treated comes from a public supply (and therefore comply with current legislation), this equipment will substantially improve the quality of water. Otherwise, it will be necessary to carry out a physical-chemical and bacteriological analysis of the water, in order to ensure its correct purification by applying the appropriate techniques and equipment to each need, PRIOR TO THE INSTALLATION of the equipment. Get in touch with your distributor in order to be advised on the most appropriate treatment for your case.

The water treatment equipment needs periodic maintenance carried out by qualified technical personnel in order to guarantee the quality of the water produced and supplied.

#### 4.1 Conditions for the correct functioning of the equipment

- Do not feed the equipment with hot water ( $T > 40^{\circ}\text{C}$ ).
- The ambient temperature must be between  $4^{\circ}$  and  $45^{\circ}\text{C}$ .
- Some models incorporate a pump. In the event that the network pressure is greater than 2.5 bar, a pressure regulator must be placed prior to the water entering the equipment, set at a maximum pressure of 2.5 bar.
- For water with salinity higher than 2000 ppm consult your distributor.
- It is recommended that the water to be treated be softened or with a maximum hardness of  $15^{\circ}\text{HF}$  in order to obtain optimum performance from the equipment.
- In the event that the water to be treated has a hardness greater than  $15^{\circ}\text{HF}$ , a reduction in the life of the membrane and in the performance of the equipment could be produced.
- If the water to be treated contains:
  - Elevated concentrations of iron and manganese (Greater than 1ppm measured in the rejection of the machine).

- Prolonged hyperchlorination over time.
- Sludge or turbidity greater than 3 NTU.
- A concentration of nitrates greater than 100 ppm.
- A sulfate concentration greater than 250 ppm.
- Contact your distributor to recommend the most suitable pre-treatment for your case, and thus ensure the proper functioning of the equipment, avoid damage to components and guarantee the quality of the water supplied.

#### 4.2 Prior warnings to installation

- In case of having to condition the installation of the home or business to be able to install the equipment in the planned place, it must be done following the national regulations for interior installations of water and electrical supplies.
- COLUMBIA equipment requires an electrical outlet less than 1 meter away.
- COLUMBIA equipment should not be installed lying down or tilted. They must be placed on a flat surface for correct and safe operation.
- The place planned for its installation must have enough space for the device itself, its accessories, connections and for carrying out convenient maintenance.
- Maintain a minimum separation of 10 cm on the sides and rear wall to ensure proper ventilation of the equipment.
- Under no circumstances will the equipment be installed outdoors.

**!** **Attention: This equipment must be connected to the electrical current directly, it must be left to rest for 2 hours once it has been placed in the desired installation position. This is very important to ensure correct system operation, otherwise the compressor could be damaged. The manufacturer will not be responsible for damages caused to the equipment in this case.**

#### 4.3. Equipment use warnings

- When you are going to be away for more than a week, close the water inlet tap to the equipment, empty it and disconnect it from the power supply. When you return, connect the power supply to it, open the input key and empty the storage tank twice before consuming water.

**!** **Attention: After a prolonged period (more than a month) in which the equipment has not been working or producing water, contact your distributor in order to carry out adequate sanitization and maintenance.**

**!** **Attention: Special attention should be paid to the cleaning and hygiene of the front dispensers, on a regular basis and especially when carrying out periodic maintenance and sanitization. To do this, use the sanitizing spray and single-use absorbent paper (See the Sanitization chapter).**

**!** **Attention: The water provided by the osmosis equipment is LOW MINERALIZATION. The mineral salts that the human body needs are provided mainly by food, and to a lesser extent by drinking water.**

## 5. EQUIPMENT OPERATION

---

### 5.1 How to draw water from your dispenser

See chapter 3 of the Technical Manual to identify the dispensers and how to draw water.

### 5.2 Use of management and control components

See chapter 4 of the Technical Manual to identify and know how the management and control components work.

### 5.3 Basic system operation

In the "Filtration" models, the mains water to be treated enters the equipment through the turbidity filter and carbon filter. In this filtration stage, suspended particles, chlorine, its derivatives and other organic substances are retained.

In the "Ultrafiltration" models, the water subsequently passes through the UF membrane where the smallest particles and even viruses and bacteria will be retained. In the "Reverse Osmosis" models; The passage of water into the equipment is controlled by a solenoid valve.

The water, after the filtration stage, is driven towards the reverse osmosis membrane. Depending on the model, the equipment may incorporate a pump to increase the pressure. The pressure of the water on the membrane makes the reverse osmosis process possible.

Subsequently, the water passes through a post-filter whose purpose is the elimination of possible odors and salt.

The rejected water or with excess salts and other dissolved substances is directed towards the drain for its elimination.

When demanding water by pressing the front dispensers of the equipment, the water accumulated in the cold, hot and reserve water tanks (depending on the model) flows towards the outlet nozzles.

**!** **Attention: There are slight variations in operation, depending on the model. Read the corresponding section of the Technical Manual.**

## 6. INSTALLATION

---

The installation of your dispenser must be carried out by personnel qualified enough for it. Check with the dealer if in doubt.

**!** **Attention: Since the device to be installed improves the quality of the water that is going to be consumed, all the tools that are going to be used for assembly and installation must be clean and in no case may they be contaminated or impregnated with grease, oils or oxides. Use exclusive use tools for tube cutting, membrane manipulation, etc.**

**!** **Attention: The work must be carried out with an attitude and adequate hygienic conditions, taking extreme precautions in everything related to materials and components that are going to be in contact**

with the water to be treated or consumed.

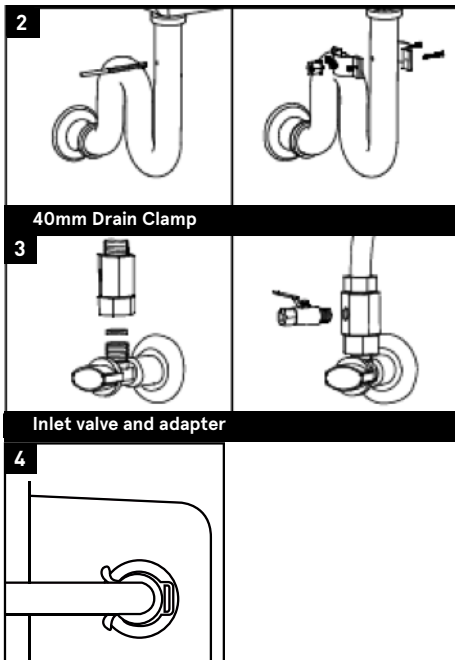

**!** Attention: Avoid the risks of external contamination of the equipment due to improper handling, using gloves, hand sanitizing gel or washing your hands as many times as necessary throughout the installation, start-up and maintenance of the equipment.

Install the drain collar, only in the RO version (image 2) and the inlet adapter (image 3) and connect them to the respective connectors of the IN (input) and OUT / DRAIN (drain) equipment, only in the RO version (image 4).

The drain pipe can be directed up a maximum of 2.5 meters vertically and another 5 meters horizontally.

Some models include a connection for emptying from the drip tray (see the Technical Manual), in this case this tube must be directed to a drain that is at a lower height than the tray since it will empty due to the weight of water.

**!** Attention: Some of the installation accessories may vary depending on the model and region in which the equipment is distributed.

Use the appropriate tools and sealants to ensure the tightness of the connections.

## 7. RINSING THE CARBON FILTERS

See chapter 6 of the Technical Manual to see how to access the filters.

It is necessary to remove the granulated carbon dust from the filters that is generated during transport and

handling of the equipment and corresponding cartridges. This dust must be removed as it could completely or partially clog the reverse osmosis membrane, as well as cause a malfunction of the equipment.

To do this, disconnect the tube that joins the outlet of the last carbon pre-filter (there may be 1 or 2 depending on the model) and the inlet to the membrane holder (See indication A, in the flow chart of the Technical Manual). Feed the equipment hydraulically (by opening the inlet valve) and electrically and direct this pipe towards an external container or sink until the water runs clear and the coal dust has been completely removed.

**!** Attention: Do not wash the carbon pre-filters through the front dispensers, as the carbon dust to be removed would enter the equipment tanks, and could cause them to malfunction and become dirty and/or reduction of the useful life of certain components.

On RO models; rinse the post-filter, to do so connect the output of the last carbon pre-filter (there may be 1 or 2 depending on the model) with the inlet of the post-carbon (See indication B, in the flow chart of the Technical Manual). Disconnect the post carbon outlet tube (See indication C, in the flowchart of the Technical Manual). Feed the equipment hydraulically (by opening the inlet valve) and electrically and direct this tube towards an external container or sink until the water runs clear and the carbon dust from the post-filter has been completely removed.

After washing the filters, leave all the tubes and components in their original position and connections.

## 8. TIGHTNESS CHECK OF THE SYSTEM, STOP AND START (RO)

Keep the inlet valve open and keep the equipment powered by performing a visual inspection of the system to ensure that there is no leakage (for about 1 minute).

## 9. CLEANING AND MAINTENANCE

### 9.1 Equipment cleaning

- Always unplug the equipment from the electrical supply before cleaning the equipment.
- Clean the exterior surfaces of the equipment with a cloth indicative, moistened with water and neutral soap.
- Never use detergent or chemicals.
- Do not spray water directly on the surface of the equipment.
- If the condenser accumulates dust or other unknown substances, clean it with a cloth moistened with water and neutral soap.
- After cleaning the equipment, dry it completely before connecting it to the power supply.

· Daily empty the drip tray.

## 9.2 Water treatment maintenance

**!** **Attention:** Some components of your equipment, such as pre-filters, membranes and post-filters (depending on the model), are consumables that have a limited duration. The duration will depend on the quality of the local water, consumption, type of use and specific aspects of the water to be treated such as extreme turbidity, high chlorination, excess iron.

**!** **Attention:** In order to guarantee the quality of the water supplied by your equipment, periodic maintenance must be carried out.

Recommended maintenance
· Sediment pre-filter: At least every 12 months*
· Carbon pre-filter: At least every 12 months*
· Osmosis membrane: Every 3 years approx. (for soft water to be treated (hardness >15°HF))
· Postfilter: At least every 12 months*
· Sanitization: At start up. At least every 12 months based on usage. Every time you access components in contact with water from the equipment or do not have consumed water for more than a month.

\* Depending on the intended use and characteristics of the water to be treated.

Maintenance must be carried out by trained personnel, who must handle the equipment properly, as well as use original spare parts to maintain the characteristics, warranty, certifications and benefits of the equipment and thus preserve the quality of the water dispensed.

**!** **Attention:** The use of non-original spare parts, installation outside the operating limits and improper start-up, maintenance or use, may lead to the loss of the guarantee, as well as the invalidation of the certifications to which the equipment has been subjected.

An excess in any compound (total chlorine, turbidity, hardness, etc.) can cause a reduction in the life of filters and certain components. These maintenances are indicative.

**!** **Attention:** All consumables are delivered with individual packaging specially designed to guarantee hygienic conditions of storage and transport. Take extreme hygienic precautions after removing the consumables from their packaging and when handling the various connectors and components.

**!** **Attention:** Before disassembling the equipment, plan all the material you will need to carry out the maintenance operations and the necessary space for it. Work in a properly lit place, in suitable hygienic conditions and with enough space to carry out operations comfortably.

Change the filters properly, depending on the model of the equipment and the type of filter. Ensure the tightness of the joints and the original hydraulic configuration of the system. See the Technical Manual for the necessary filters according to your equipment model and how to access the filters.

Sanitize the equipment following the indications described in the Sanitization Procedure.

**!** **Attention:** In case of detecting that the water dispensed does not comply with current national legislation, close the input key of the equipment, empty it through the tap, disconnect it electrically and contact your technical service.

## 10. SANITIZATION PROCEDURE

Necessary material:

- Manual valve.
- Dosing cartridge with connectors.
- Hydrogen peroxide (0.5 l). (sanitizing product)
- Single-use vinyl gloves.
- Hydrogen peroxide detector strips.
- Sanitizing spray. (Hydrogen peroxide)
- Paper napkin.

Perform a sanitization of the equipment during start-up, when appropriate (every time there is a risk of contamination of the equipment by handling components in contact with water) or with the indicated periodicity.

To do this, follow the steps below:

**!** **Attention:** The water used during sanitization must be potable water (from a public distribution network, complying with the corresponding potability requirements of RD 140 / 2003, European directive 98 / 83 or current local legislation).

· Keep the inlet valve closed (6) and empty the accumulation tank through the front dispensers (see chapter "how to extract water").

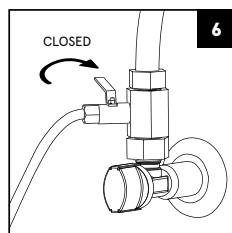

· Sanitization must be carried out with the new pre- and post-filters installed and properly rinsed beforehand, correctly removing carbon dust from them.

· Use single-use vinyl gloves to handle sanitizing products.

### 10.1 Sanitizing the pre-filters and membrane

Insert the dosing cartridge into the equipment inlet

tube.

For it:

- Disconnect the inlet pipe to the equipment marked "IN", and insert the dosing cartridge between the inlet valve and the water inlet of the equipment (8). For greater comfort and ease of access during sanitization and the opening and closing operations of the inlet valve, you can insert, together with the sanitizing dosing cartridge, a manual valve in the closed position, which will perform the same functions as the inlet valve.

- Once the assembly is installed, keep the new inlet valve closed and open the inlet valve (9). The dosing cartridge should initially be empty.

- Pour 100 ml of sanitizing product into the dosing cartridge inserted in the equipment inlet (10). Screw the glass correctly to its head.

- On RO models. Connect the equipment to the power supply.

- Open the water inlet valve to the equipment, allowing it to start working and allowing the sanitizing product to be pushed towards it. Keep the inlet valve in that position and let the equipment run for 10 minutes for reverse osmosis models and 3 minutes for Filtration and Ultrafiltration models.

- Close the inlet valve (11) and unplug the equipment from the electrical supply, wait for the equipment to stop pouring water through the rejection outlet towards the drain (reverse osmosis models only).

pensers and purge outlet (12). Refill the tanks and empty them to rinse the sanitizing product remains.

- Remove the complementary elements used for Sanitization and reconnect the power tube to the input (IN) of the equipment.

- Open the inlet valve and electrically feed the equipment so that it starts up.

- Use the sanitizing product detection strips (318701) to verify that the equipment is properly rinsed, make the necessary empties in case of detecting sanitizing product remains.

## 11. INTERFACE WITH THE USER

**!** Attention: Depending on the model, the equipment may incorporate an electronic controller that will efficiently manage the functionality and status indications in which it is located, as well as the different security systems.

If it is incorporated, see points 3 and 4 of the equipment's Technical Manual where the states in which each system can be found and the information provided by it are described.

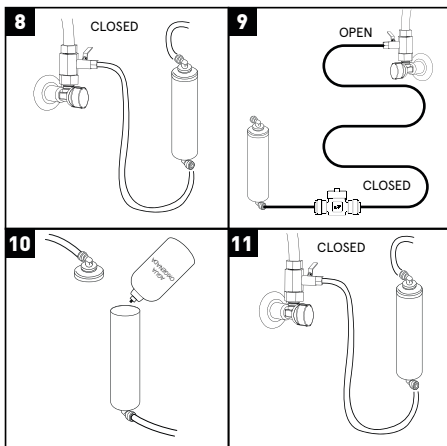

- Let the filters soaked with the Product rest for 20 minutes. Meanwhile proceed to sanitize the deposits.

### 10.2 Sanitization of tanks and front dispenser

- Sanitize the nozzles of the front dispensers using cotton swabs and sanitizing spray.

- Completely empty the deposits through the front dis-

## 12. . SOLUTION OF PROBLEMS

THE TANK IS NOT FILLED AT ALL		
Problem	Cause	Solution
<b>1. No water enters the dispenser</b>	The inlet valve is closed	Open the inlet valve
	The dispenser is unplugged	Plug the dispenser into the mains
	The switch is OFF	Position the switch to ON
	No water supply	Non-dispenser problem
	Obstruction in the feeding tube to the dispenser	Change the feeding tube
<b>2. Water enters the dispenser, but does not reach the membrane</b>	Solenoid valve does not open	See point 3
	There is a clogged filter	Disconnect the output of each filter one by one to locate the clogged filter and replace it
<b>3. The solenoid valve does not open</b>	No power to the solenoid valve	The tank is full and there is no demand for water
	The solenoid valve is damaged, since current reaches it and it does not open (Check with a voltmeter)	Replace the solenoid valve
<b>4. The solenoid valve and the pump do not work</b>	Level switch does not working	See point 6
<b>5. The solenoid valve opens, but the pump does not work</b>	Cable is disconnected	Check that there are no loose wires
	Pump is damaged	Change the pump
<b>6. The level switch does not work</b>	It is damaged and does not respond to raising and lowering the float	Change the level switch
	The electronic card is damaged	Change the electronic card
PRODUCTION IS LITTLE		
<b>7. Production is low</b>	Partial clogging of the sediment filter, comparing the inlet flow rate with the outlet flow rate of the sediment cartridge	Change the sediment filter
	Partial obstruction of the solenoid valve, comparing the inlet flow rate with the outlet flow rate of the solenoid valve	Change solenoid valve
	The membrane is clogged	See point 8
<b>8. The membrane is clogged</b>	The equipment does not reject water	Change flow restrictor and membrane
	The membrane is more than 3 years old	Change membrane
	The TDS of the inlet water is greater than 1500 ppm	Contact your service representative

<b>WATER DOES NOT STOP COMING OUT OF THE DRAIN</b>		
<b>9. The dispenser never stops pouring water down the drain</b>	The level switch does not respond to the full tank command (Check with a voltmeter)	Cambiar el interruptor de nivel.
	The inlet solenoid valve has stuck since it does not close when the electrical current is disconnected	Cambie la electroválvula de entrada.
<b>WATER QUALITY IS NOT GOOD</b>		
<b>10. The water quality is not correct</b>	The rejection flow is much less than 0.5 liters per minute	Reemplace el restrictor de caudal de rechazo
	The membrane has reached the end of its useful life and no longer removes 90% of the salts from the inlet water	Cambie la membrana.
<b>11. The water tastes bad</b>	The taste is like bitter, metallic or plastic and the output TDS is less than 25	Reemplace el postfiltro por un cartucho remineralizador.
	The dispenser is contaminated	Realice una higienización completa de la fuente.
<b>LA FUENTE NO ENFRÍA O SALE POCA AGUA FRÍA</b>		
<b>12. The water does not come out cold</b>	The rear switch (COLD) is in the OFF position	Pulse el interruptor a ON.
	The customer takes out bottles of cold water and empties the cold water tank	Las fuentes están diseñadas para que se saque el agua vaso a vaso.
	The cold system is damaged or the refrigerant gas has been lost	Retire la fuente para su reparación en taller.
<b>THE DISPENSER DOES NOT HEAT OR LITTLE HOT WATER COMES OUT</b>		
<b>13. The water does not come out hot</b>	The rear switch (HOT) is in the OFF position	Push the switch to ON
	The hot tank thermostat is damaged	Change the thermostat of the hot tank
	The resistance is damaged	Change the resistance

# 1. TECHNICAL CHARACTERISTICS

## APPLICATION

ROP Model (Reverse Osmosis)  
 F Models (Filtration)  
 UF (Ultrafiltration) models

### Use

Improvement of the characteristics of drinking water (that complies with the requirements of the European Directive on water for human consumption 98/83 or its national transpositions in the different member states of the European Community).

### Modifications due to reduction or contribution

#### Model ROP

- Water treatment by reverse osmosis is capable of reducing the concentration of salts and other substances in high percentages.
- Minimal reduction\* of certain compounds and parameters:
  - Sodium – 90 %
  - Calcium – 90%
  - Sulphate – 90%
  - Chloride – 90%
  - Total hardness – 90%
  - Conductivity – 90%

(\*) Depending on the characteristics of the water to be treated (at the membrane outlet). These values may vary depending on the type of postfilter that the equipment incorporates.

#### Model F

- Water treatment by filtration retains suspended particles with a diameter greater than 5 microns.
  - The carbon filter reduces\* the taste and odor of the water, as well as organic components.
- (\*) Depending on the characteristics of the water to be treated.

#### Modelo UF

- These equipments consist of a first stage of Filtration.
  - Ultrafiltration water treatment is capable of retaining suspended particles with a diameter between 0.1 and 0.001 microns.
- (\*) Depending on the characteristics of the water to be treated.

WORKING LIMITS	ROP	UF	F
<b>Pressure (max. / min.)</b>	2,5 bar (250 kPa) 1 bar (100 kPa)	5 bar (500 kPa) 1 bar (100 kPa)	5 bar (500 kPa) 1 bar (100 kPa)
<b>TDS (máx.)</b>	2000 ppm	-	-
<b>Temperature (max. / min.)</b>	40°C - 2°C	40°C - 2°C	40°C - 2°C
<b>Hardnes (max.)</b>	15°HF**	-	-

TECHNICAL DATA	ROP	F	UF
<b>Control type:</b>	Level switch. Inlet solenoid valve. Cold water thermostat. Hot water thermostat.	Cold water thermostat. Hot water thermostat.	Cold water thermostat. Hot water thermostat.
<b>Security system:</b>	Hot water thermal safety protector	Hot water thermal safety protector	Hot water thermal safety protector
<b>Inlet connection:</b>	1/4"	1/4"	1/4"
<b>Drain connection:</b>	1/4"	-	-
<b>Wall adapter:</b>	1/2"	1/2"	1/2"
<b>Drain collar:</b>	40mm drain pipe clamp	-	-



**TECHNICAL DATA**

	<b>ROP</b>	<b>F</b>	<b>UF</b>
<b>Treatment</b>	1 sediment prefilter 2 GAC prefilers 1 BLOCK prefilter 1 RO 50 GPD membrane 1 carbon postfilter	1 sediment prefilter 1 carbon prefilter	1 sediment prefilter 1 carbon prefilter 1 ultrafiltration prefilter 1 carbon prefilter
<b>Dimensions:</b>	(A x B x C) 1115 x 300 x 390 mm		
<b>Weight:</b>	18 kg		
<b>TANKS TOTAL VOLUME</b>			
<b>Cold water tank:</b>	5 liters total volume		
<b>Hot water tank:</b>	2 liters		
<b>Power supply</b>	220 – 240 Vac		
<b>REFRIGERATION SYSTEM</b>			
<b>Compressor:</b>	1/10 CV sealed		
<b>Compressor power:</b>	85 W		
<b>Condenser:</b>	Capillarytype		
<b>Refrigerant gas:</b>	R600a		
<b>Temperature control:</b>	Adjustable thermostat		
<b>HEATING SYSTEM</b>			
<b>Heater:</b>	Band		
<b>Heater power:</b>	500 W		
<b>Temperature control:</b>	Termostato Bimetal		
<b>Protección sobrecalentamiento:</b>	Bi-metal auto-armable		

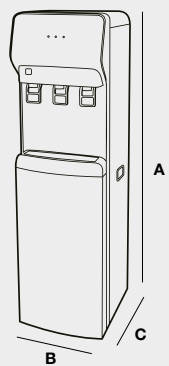

**ROP MODEL HYDRAULICAL DIAGRAM**

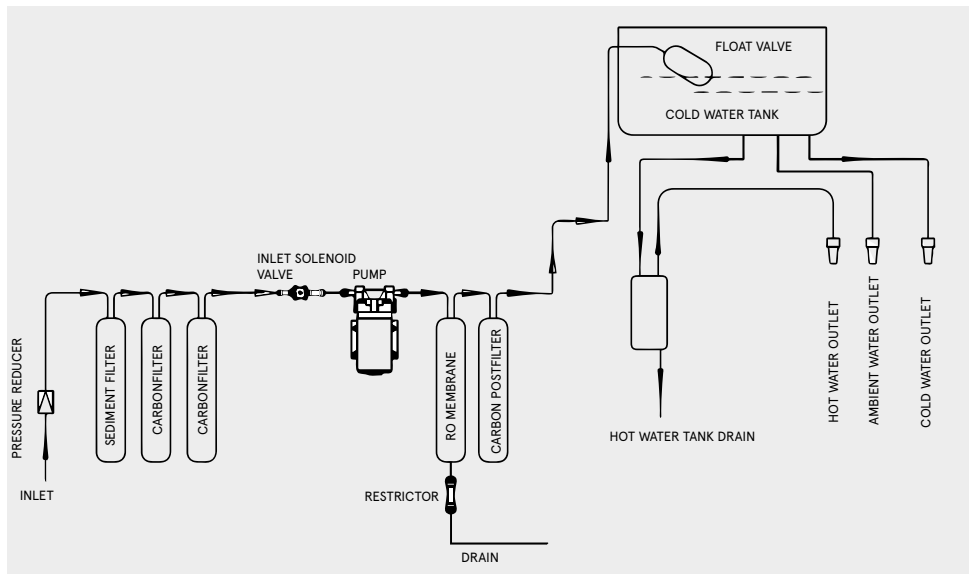

### ROP MODEL HYDRAULICAL DIAGRAM

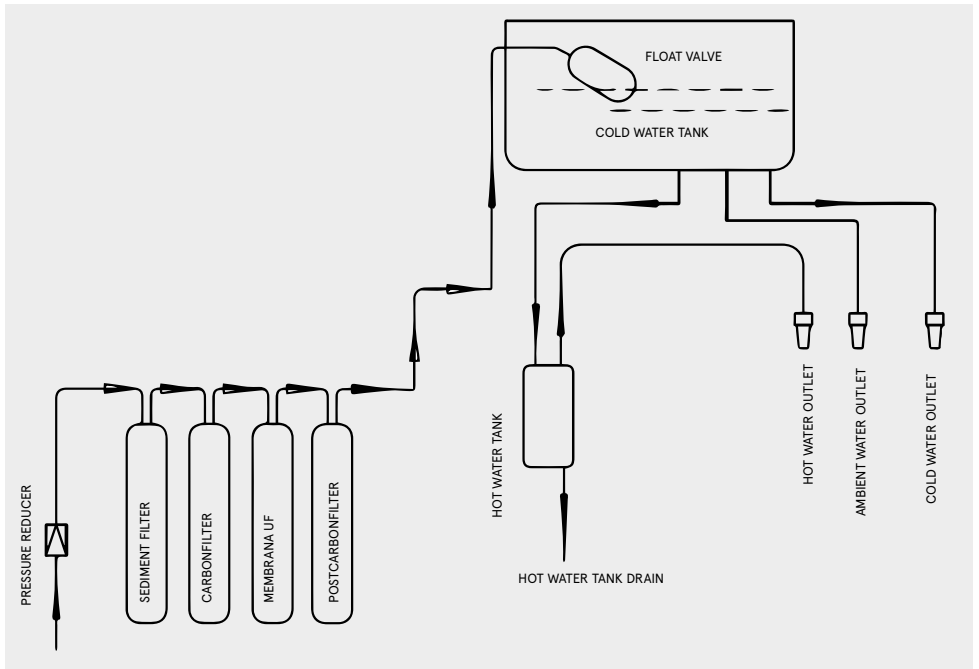

### F MODEL HYDRAULIC DIAGRAM

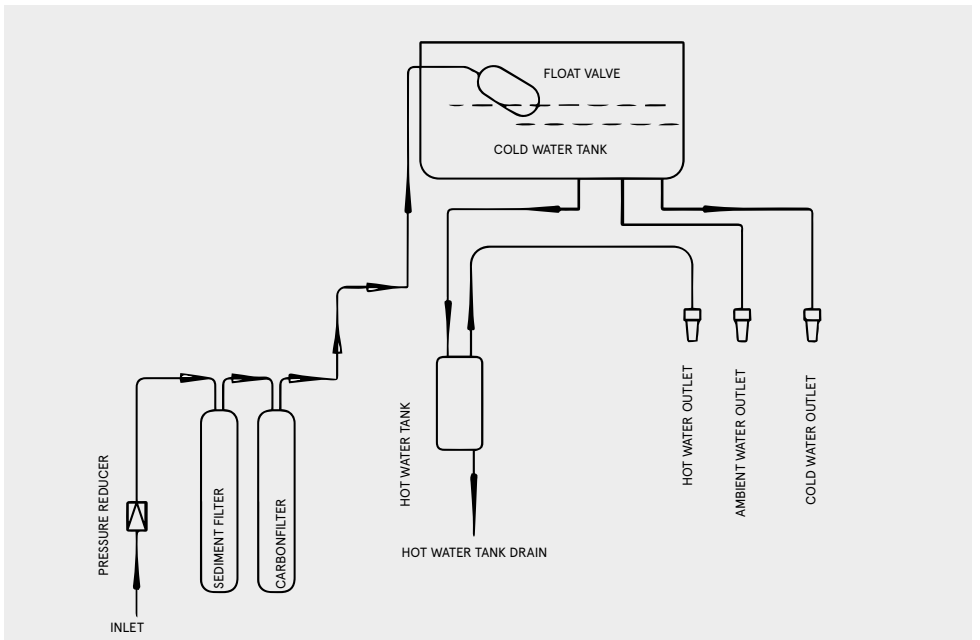

**ROP MODEL ELECTRICAL DIAGRAM**

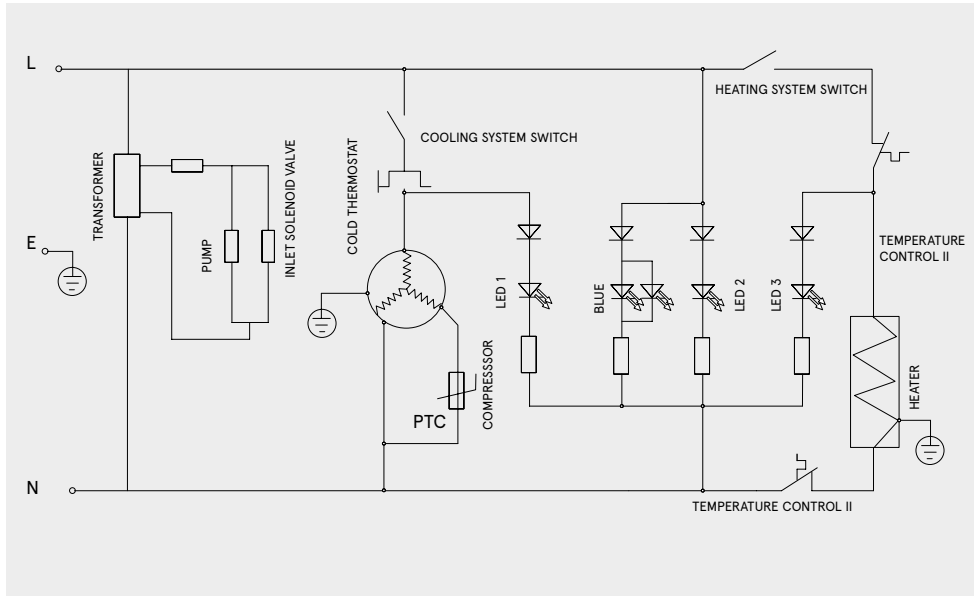

**F/UF MODEL ELECTRICAL DIAGRAM**

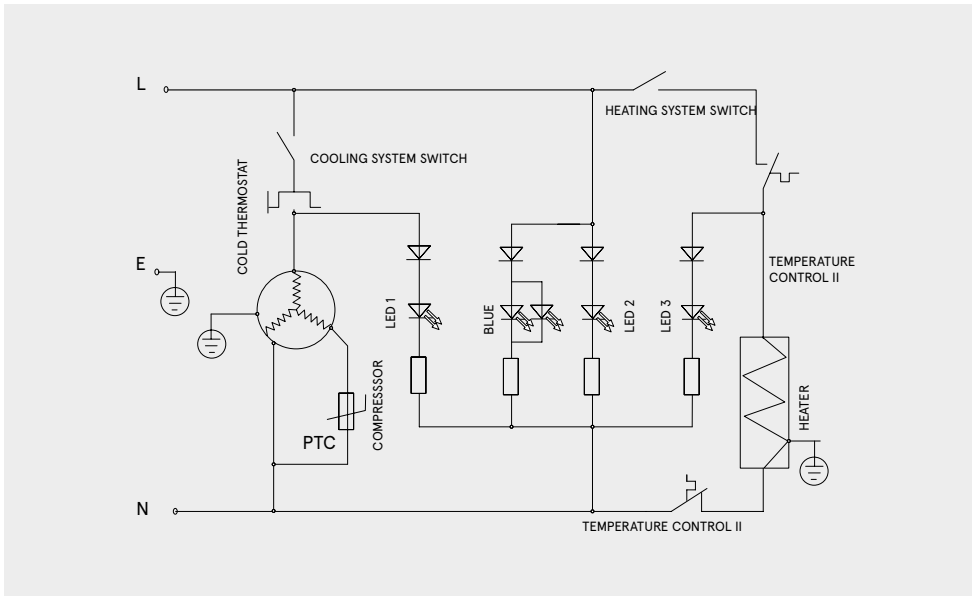

**HYDRAULIC CONNECTION DIAGRAM ROP MODEL**

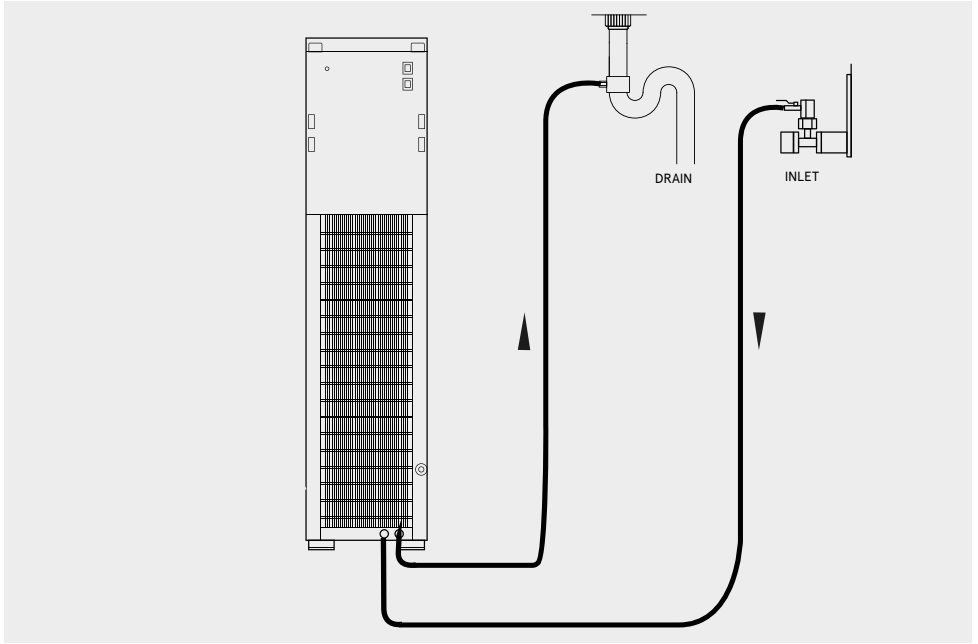

**HYDRAULIC CONNECTION DIAGRAM F/UF MODEL**

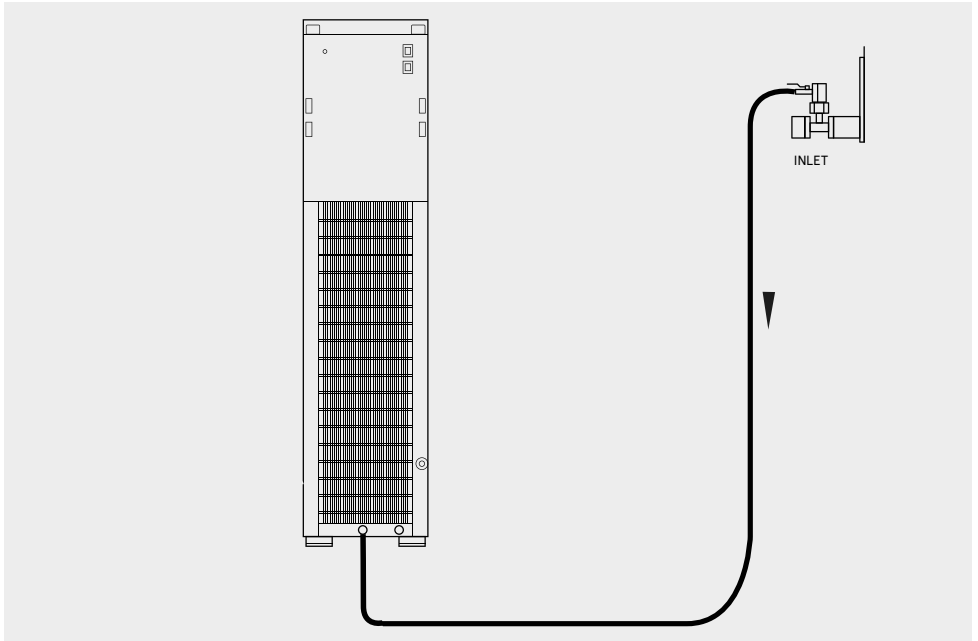

## 2. IDENTIFICATION OF MANAGEMENT AND CONTROL COMPONENTS

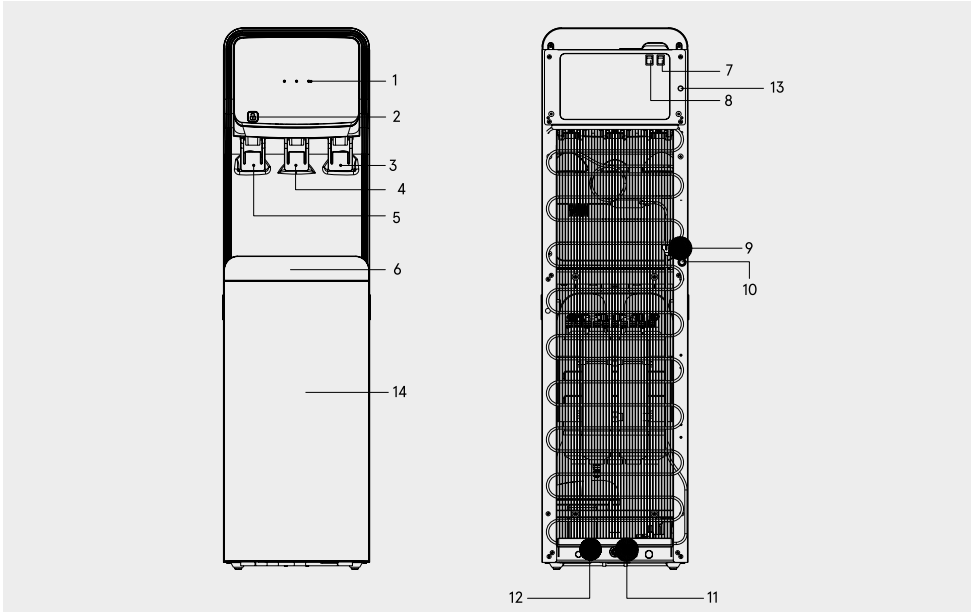

### 1. Status indicators.

Red light on the left indicates that the water heating system is heating.

Yellow light in the center indicates that the equipment is electrically powered.

Blue light on the right indicates that the cooling system is cooling.

### 2. Safety lock.

Press this button before operating the lever to draw off hot water.

### 3. Cold water tap.

Press this lever with a glass or bottle to draw cold water.

### 4. Ambient water tap.

Press this lever with a glass or bottle to draw ambient water.

### 5. Hot water tap.

Press the lock button and then press this lever to draw hot water.

### 6. Drip tray.

Empty this tray daily to prevent it from overflowing.

### 7. Hot system switch.

Activate the switch if you want hot water to be available in the dispenser. If you keep it in the OFF position, you can draw ambient water from the hot tap.

### 8. Cold system switch.

Activate the switch if you want cold water to be available in the dispenser. If you keep it in the OFF position, you can draw ambient water from the cold tap.

### 9. Power cable.

### 10. Emptying the hot tank.

Remove the plug to empty the hot water tank in case of breakdown, maintenance or any other need. Take the necessary precautions to avoid burns as the water could be very hot.

### 11. RO rejection outlet.

### 12. Mains water inlet.

### 13. Adjustable cold thermostat.

Turn clockwise for colder water. Turn counterclockwise for less cold water.

### 14. Filter housing.

### 3. HOW TO DRAW WATER FROM THE DISPENSER

To draw cold water: Press the lever on the right side of the dispenser with the glass to let the cold water flow (1).

To draw ambient water (if your dispenser model is equipped with it): Press the lever at the centre of the dispenser with the glass to let the ambient water flow (1). Draw hot water: Press and hold down the release button on the left-hand faucet and then press the lever at the center of the dispenser with the tumbler to make the hot water flow (1). and then press the lever on the left-hand side with the tumbler to let the hot water flow (2).

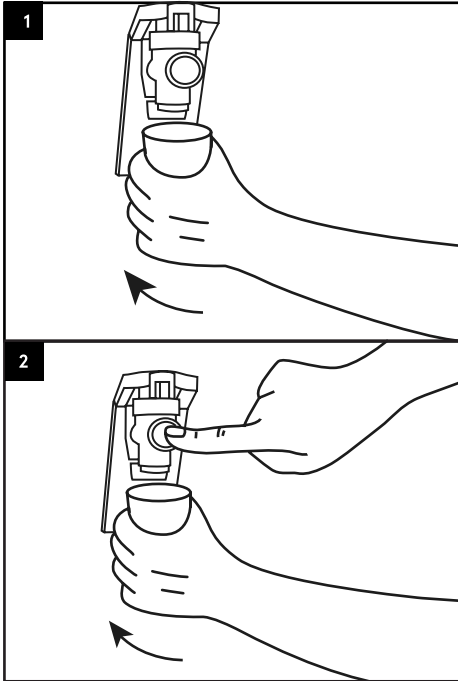

### 4. USER INTERFACE



The hot light, lit in red, indicates that the system is active and is heating the water.



The power light indicates that the equipment is correctly plugged in.



The cool light, lit in blue, indicates that the cooling system is active and is cooling the water.

### 5. HOW TO ACCESS THE FILTERS

Grasp the lower front cover with both hands and pull it away from the unit while pulling it slightly downward.

### 6. USER MAINTENANCE

Empty the dispenser drip tray daily if it is not connected to a drain. To remove it, hold it by the sides and pull it upwards. Periodically spray the water outlet nozzles of the faucets with hydrogen peroxide spray, let it stand for a few minutes and draw a few glasses of water for rinsing.

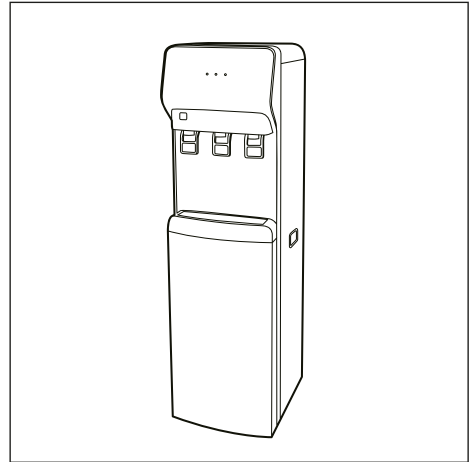

## 7. WARRANTY

This equipment has a warranty period as established in the legislation in force.

- The warranty includes the repair and replacement of defective parts by personnel authorized by the distributor or by the official technical assistance service (T.A.S.) at the place of installation or at its workshops. Labor and shipping costs that may be incurred are included in the warranty.
- The distributor is exonerated from providing warranty in cases of parts subject to natural wear and tear, lack of maintenance, knocks or other non-conformities resulting from improper or inadequate use of the equipment according to the operating conditions and limits indicated by the equipment manufacturer. Likewise, the warranty loses effectiveness in cases of improper handling and use of the equipment or in those cases in which they have been modified or repaired by personnel outside the distribution company or official S.A.T.
- The parts replaced under warranty will remain the property of the distributor.
- The distributor is responsible for the lack of conformity of the equipment when this refers to the origin, identity or suitability of the products, according to their nature and purpose. Taking into account the characteristics of the equipment, it is essential for the warranty to cover the lack of conformity, the fulfillment of the technical conditions of installation and operation. Failure to comply with these conditions may result in the absence of warranty, taking into account the relevance of the purpose of the equipment and the operating conditions and limits under which it must operate.
- The distributor must guarantee that the equipment installed is suitable for the improvement of the quality of the water to be treated in particular, according to the characteristics of the equipment and the regulations in force.
- The distributor must guarantee the correct installation and commissioning of the equipment as indicated by the manufacturer and current regulations and will also be responsible for the lack of conformity derived from an incorrect application, installation or commissioning of the equipment.
- For any warranty claim it is necessary to present the purchase invoice. The period is calculated from the purchase of the equipment from the distributor.
- If during the warranty period your equipment presents any problem, please contact your distributor.

The equipment is installed and operating to the customer's satisfaction and for the record:

\* Pre-treatment of the equipment:

\* Hardness of entry to the equipment (°F):

\* TDS input to the equipment (ppm):

\* TDS produced water (ppm):

\* Pressure of entry to the equipment (bar):

\*Result of the installation and commissioning sheet:

Correct:

Others:

The owner of the equipment has been properly and clearly informed of the use, handling and maintenance that the equipment requires to ensure its proper functioning and the quality of the water produced. A maintenance contract is offered for this purpose.

\*Ref: Maintenance contract:

ACCEPTS the maintenance contract

DOES NOT ACCEPT the maintenance contract

If you need information, report a malfunction or malfunction, request for maintenance or intervention by a technician, please read the operation, troubleshooting and troubleshooting sections of this manual beforehand and contact the distributor or company that sold you your equipment.

COMPANY AND/OR AUTHORIZED INSTALLER, DATE AND SIGNATURE:

SERIAL NUMBER:



**NOTE TO THE COMPANY AND/OR AUTHORIZED TECHNICIAN/INSTALLER: the data marked with the \* symbol must be filled in by the installer and transcribed by him/herself from the INSTALLATION REGISTRATION sheet.**

## 8. INSTALLATION REGISTER SHEET



**NOTES TO THE TECHNICIAN/INSTALLER:** read this manual carefully. If in doubt, contact your dealer's Technical Support Service (T.A.S.). The data marked with the symbol \* must be filled in by the technician/installer and transcribed by him/herself to the WARRANTY page. This sheet must be kept by the installer and may be requested by the distributor in order to improve after-sales service and customer service. The technician who performs the installation and commissioning of the equipment must have adequate technical training.

### INFORMATION ON THE USE OF THE EQUIPMENT:

Origin of the water to be treated:

PUBLIC SUPPLY NETWORK

OTHER \_\_\_\_\_

\* Pre-treatment of the equipment: \_\_\_\_\_

\* Hardness of entry to the equipment (°F): \_\_\_\_\_

\* TDS of entry to the equipment (ppm): \_\_\_\_\_

\* TDS produced water (ppm): \_\_\_\_\_

Inlet pressure to the equipment (bar): \_\_\_\_\_

### INSTALLATION STEP CONTROL:

Pre-filter assembly: \_\_\_\_\_

Overflow installation: \_\_\_\_\_

Start-up according to protocol: \_\_\_\_\_

Checking of fittings: \_\_\_\_\_

Measurement of inlet hardness: \_\_\_\_\_

Output hardness measurement: \_\_\_\_\_

Installation of isolation by-pass: \_\_\_\_\_

Correct drainage installation: \_\_\_\_\_

Brine suction test/tank filling: \_\_\_\_\_

Leakage of the pressurised system: \_\_\_\_\_

Programming of the equipment: \_\_\_\_\_

Adjustment of residual hardness: \_\_\_\_\_

### COMMENTS

\* Result of installation and commissioning:

CORRECT (equipment installed and working correctly. Produced water suitable for the application).

OTHER: \_\_\_\_\_

### IDENTIFICATION OF THE AUTHORISED TECHNICIAN/INSTALLER: CONFORMITY OF THE OWNER OF THE EQUIPMENT:

COMPANY AND/OR AUTHORIZED INSTALLER, DATE AND SIGNATURE: \_\_\_\_\_

*I have been clearly informed of the use, operation and maintenance required by the installed equipment, having been offered a maintenance contract and informed of how to contact a customer service in the event of a request for information, communication of a breakdown or malfunction, request for maintenance or intervention by a technician.*

Remarks: \_\_\_\_\_

\*Ref: Maintenance contract: \_\_\_\_\_

ACCEPTS the maintenance contract

DOES NOT ACCEPT the maintenance contract

Model/Ref: \_\_\_\_\_

Owner: \_\_\_\_\_

Street \_\_\_\_\_

Telephone: \_\_\_\_\_

City: \_\_\_\_\_

Province: \_\_\_\_\_

C.P.: \_\_\_\_\_

SERIAL NUMBER

### EQUIPMENT WARRANTY DIRECTED TO THE DISTRIBUTOR:

The distributor will only be responsible for the replacement of parts in the event of non-conformity. The repair of the equipment and the costs involved (labour, shipping costs, travel, etc.) will be borne by the distributor, in accordance with the general conditions of contract and sale, so it can not be passed on later to the manufacturer.



## 9. MAINTENANCE SERVICE

DATE	TYPE OF SERVICE	NAME, SIGNATURE AND STAMP OF TECHNICIAN	
<input type="text"/>	<input type="radio"/> START-UP		
<input type="text"/> <input type="text"/> <input type="text"/> <input type="text"/>	<input type="radio"/> COMPLETE MAINTENANCE  <input type="radio"/> PREPARATION  <input type="radio"/> SANITIZATION  <input type="radio"/> OTHERS	TECHNICIAN <input type="text"/> STAMP <input type="text"/>	<input type="radio"/> ORDINARY  <input type="radio"/> EXTRAORDINARY  <input type="radio"/> WARRANTY
<input type="text"/> <input type="text"/> <input type="text"/> <input type="text"/>	<input type="radio"/> COMPLETE MAINTENANCE  <input type="radio"/> PREPARATION  <input type="radio"/> SANITIZATION  <input type="radio"/> OTHERS	TECHNICIAN <input type="text"/> STAMP <input type="text"/>	<input type="radio"/> ORDINARY  <input type="radio"/> EXTRAORDINARY  <input type="radio"/> WARRANTY
<input type="text"/> <input type="text"/> <input type="text"/> <input type="text"/>	<input type="radio"/> COMPLETE MAINTENANCE  <input type="radio"/> PREPARATION  <input type="radio"/> SANITIZATION  <input type="radio"/> OTHERS	TECHNICIAN <input type="text"/> STAMP <input type="text"/>	<input type="radio"/> ORDINARY  <input type="radio"/> EXTRAORDINARY  <input type="radio"/> WARRANTY
<input type="text"/> <input type="text"/> <input type="text"/> <input type="text"/>	<input type="radio"/> COMPLETE MAINTENANCE  <input type="radio"/> PREPARATION  <input type="radio"/> SANITIZATION  <input type="radio"/> OTHERS	TECHNICIAN <input type="text"/> STAMP <input type="text"/>	<input type="radio"/> ORDINARY  <input type="radio"/> EXTRAORDINARY  <input type="radio"/> WARRANTY
<input type="text"/> <input type="text"/> <input type="text"/> <input type="text"/>	<input type="radio"/> COMPLETE MAINTENANCE  <input type="radio"/> PREPARATION  <input type="radio"/> SANITIZATION  <input type="radio"/> OTHERS	TECHNICIAN <input type="text"/> STAMP <input type="text"/>	<input type="radio"/> ORDINARY  <input type="radio"/> EXTRAORDINARY  <input type="radio"/> WARRANTY

## 9. MAINTENANCE SERVICE

DATE	TYPE OF SERVICE	NAME, SIGNATURE AND STAMP OF TECHNICIAN	
<input type="text"/>	<input type="radio"/> START-UP		
<input type="text"/>	<input type="radio"/> COMPLETE MAINTENANCE	TECHNICIAN <input type="text"/>	<input type="radio"/> ORDINARY <input type="radio"/> EXTRAORDINARY <input type="radio"/> WARRANTY
<input type="text"/>	<input type="radio"/> PREPARATION	STAMP	
<input type="text"/>	<input type="radio"/> SANITIZATION	<input type="text"/>	
<input type="text"/>	<input type="radio"/> OTHERS		
<input type="text"/>	<input type="radio"/> COMPLETE MAINTENANCE	TECHNICIAN <input type="text"/>	<input type="radio"/> ORDINARY <input type="radio"/> EXTRAORDINARY <input type="radio"/> WARRANTY
<input type="text"/>	<input type="radio"/> PREPARATION	STAMP	
<input type="text"/>	<input type="radio"/> SANITIZATION	<input type="text"/>	
<input type="text"/>	<input type="radio"/> OTHERS		
<input type="text"/>	<input type="radio"/> COMPLETE MAINTENANCE	TECHNICIAN <input type="text"/>	<input type="radio"/> ORDINARY <input type="radio"/> EXTRAORDINARY <input type="radio"/> WARRANTY
<input type="text"/>	<input type="radio"/> PREPARATION	STAMP	
<input type="text"/>	<input type="radio"/> SANITIZATION	<input type="text"/>	
<input type="text"/>	<input type="radio"/> OTHERS		
<input type="text"/>	<input type="radio"/> COMPLETE MAINTENANCE	TECHNICIAN <input type="text"/>	<input type="radio"/> ORDINARY <input type="radio"/> EXTRAORDINARY <input type="radio"/> WARRANTY
<input type="text"/>	<input type="radio"/> PREPARATION	STAMP	
<input type="text"/>	<input type="radio"/> SANITIZATION	<input type="text"/>	
<input type="text"/>	<input type="radio"/> OTHERS		
<input type="text"/>	<input type="radio"/> COMPLETE MAINTENANCE	TECHNICIAN <input type="text"/>	<input type="radio"/> ORDINARY <input type="radio"/> EXTRAORDINARY <input type="radio"/> WARRANTY
<input type="text"/>	<input type="radio"/> PREPARATION	STAMP	
<input type="text"/>	<input type="radio"/> SANITIZATION	<input type="text"/>	
<input type="text"/>	<input type="radio"/> OTHERS		



